

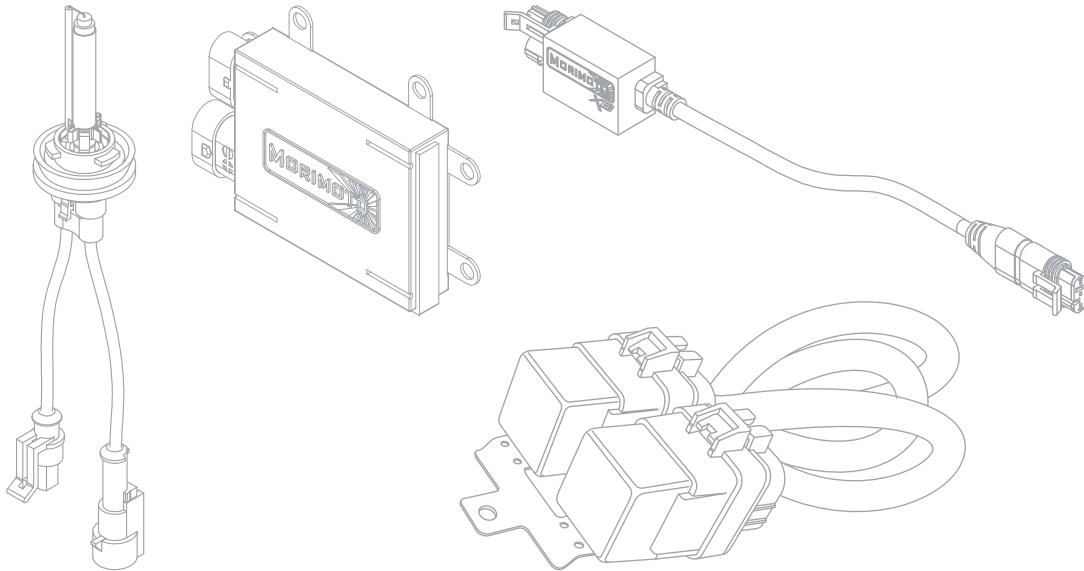

THE AUTOMOTIVE LIGHTING BENCHMARK



INSTALLATION GUIDE

2016 TACOMA-SPECIFIC ELITE HID SYSTEM



WARNING: By reading this document, I agree it is only to be used as an educational guide. Morimoto Lighting makes no guarantee on any finished results, nor are they to be held responsible for any damage, misuse, or personal injuries. Use at your own risk. If you are unable to clearly understand and adapt the information below to your own application, professional installation is recommended.

TABLE OF CONTENTS

SYSTEM DIAGRAM	P.3
HARNESS INSTALLATION	P.4
BULB INSTALLATION	P.5
BALLAST INSTALLATION	P.6

KIT CONTENTS

STANDARD PARTS



1x TEST LEAD

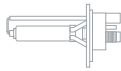

2x HID BULBS

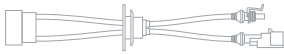

2x BULB WIRES

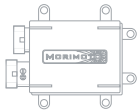

2x BALLAST COMPUTERS



2x AMP IGNITERS

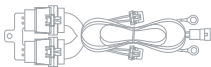

1x HD RELAY HARNESS

OPTIONAL PARTS



2x CARBON FIBER
BALLAST BRACKETS



Ballast Test Lead

The included ballast test lead is used for troubleshooting purposes only and is not part of the installation of this system. If necessary, the test lead can be plugged into the ballast input and then connected to a 12V+ source to test the ballast. This must be done with the bulb connected to the ballast prior to applying power.

SYSTEM DIAGRAM



NOTE: System diagrams are to be used for reference purposes only. If you are unsure of the installation procedure for any individual part, review its install procedure prior to proceeding.

Passenger Side

Driver Side

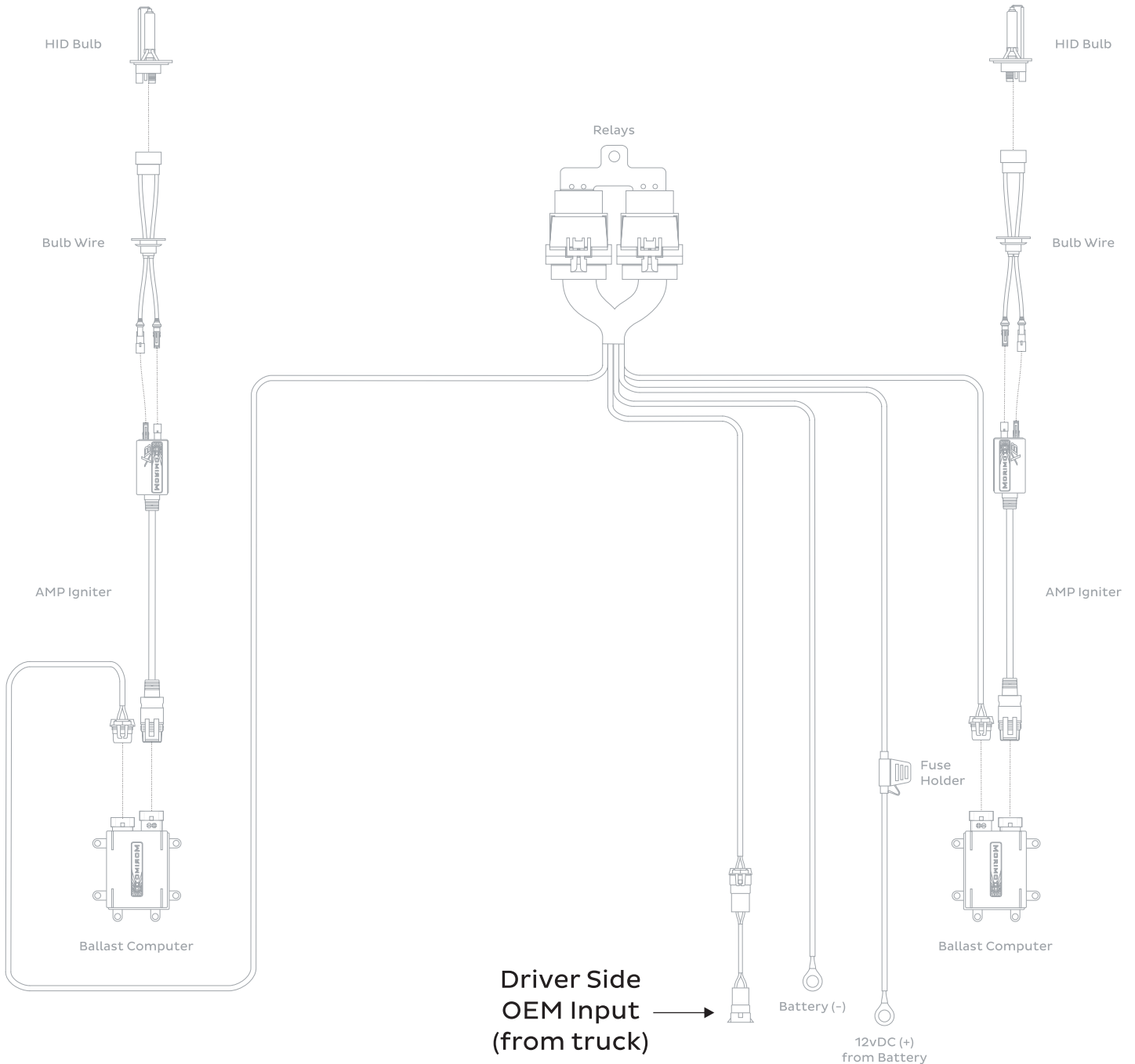

HARNESS INSTALLATION

SPECIAL NOTES

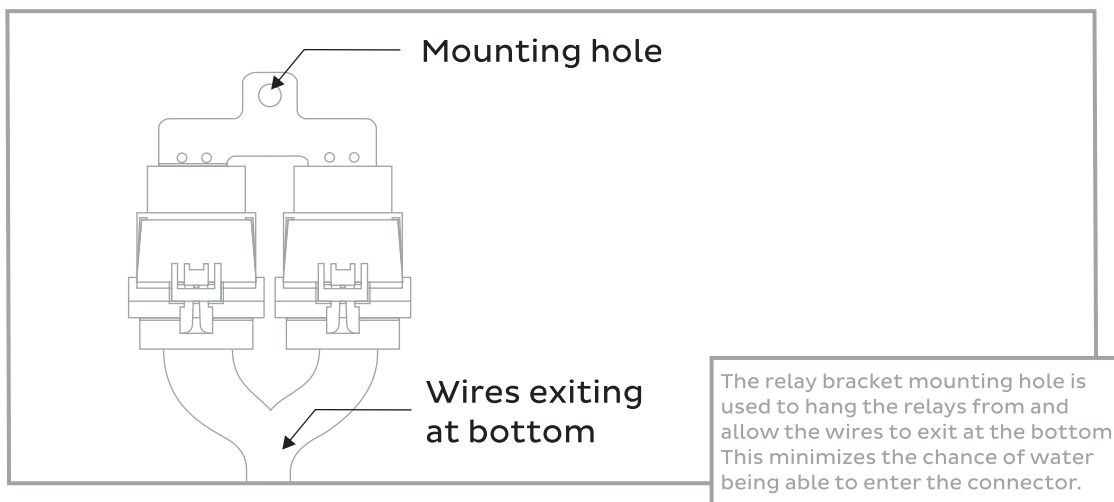
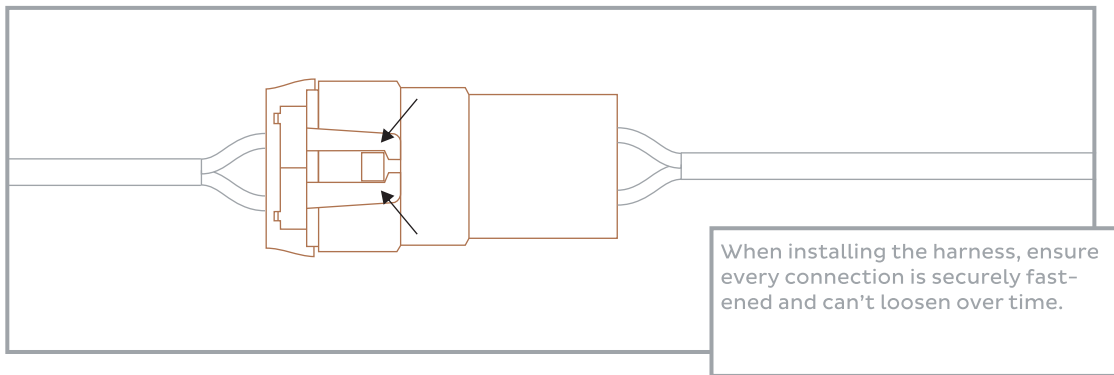

BULB INSTALLATION



CAUTION: HOT!



HANDLE ONLY WITH
BLACK PLASTIC BASE

1

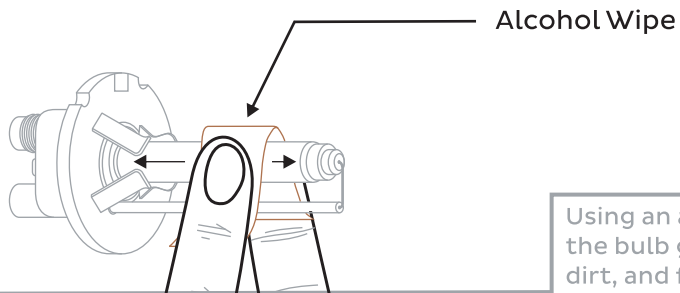

Using an alcohol wipe, clean the bulb glass of any dust, dirt, and finger prints.

2

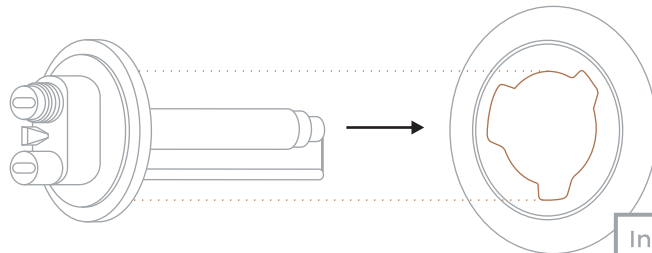

Install bulb into housing, replacing the stock halogen bulb.

3

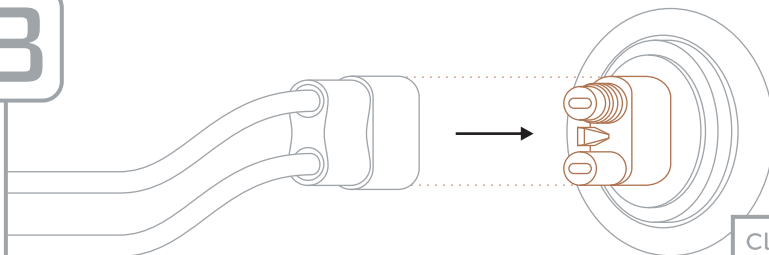

Click bulb wire connection onto bulb. Ensure side tab is fully latched.

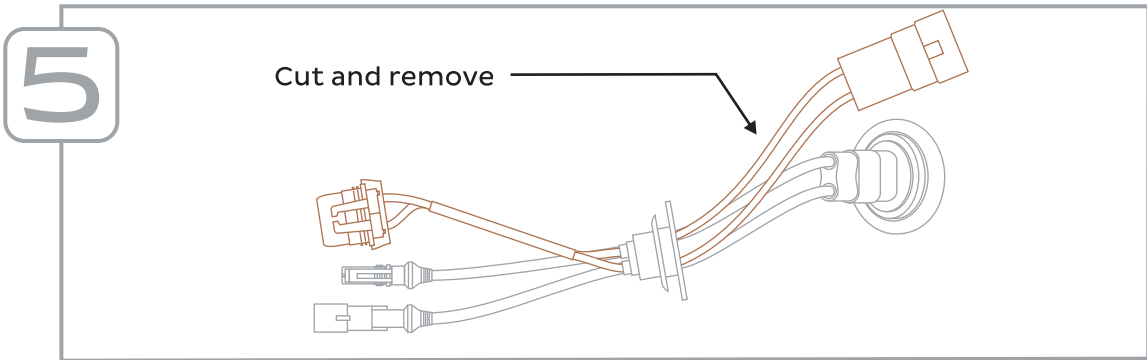
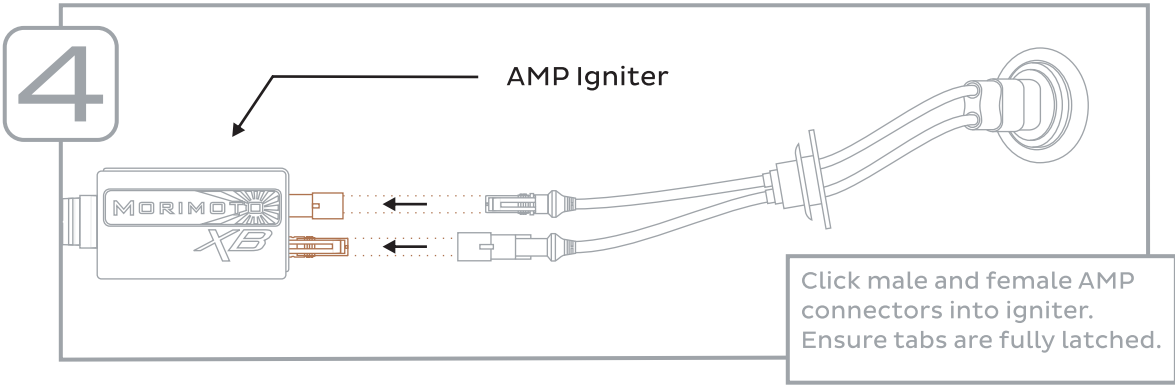

BALLAST INSTALLATION



DO NOT IGNITE UNTIL FULLY CONNECTED!



WATERPROOF

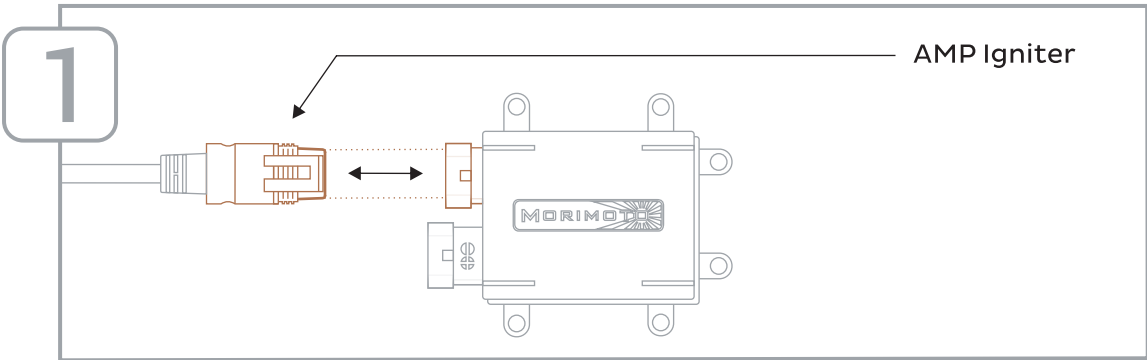

2

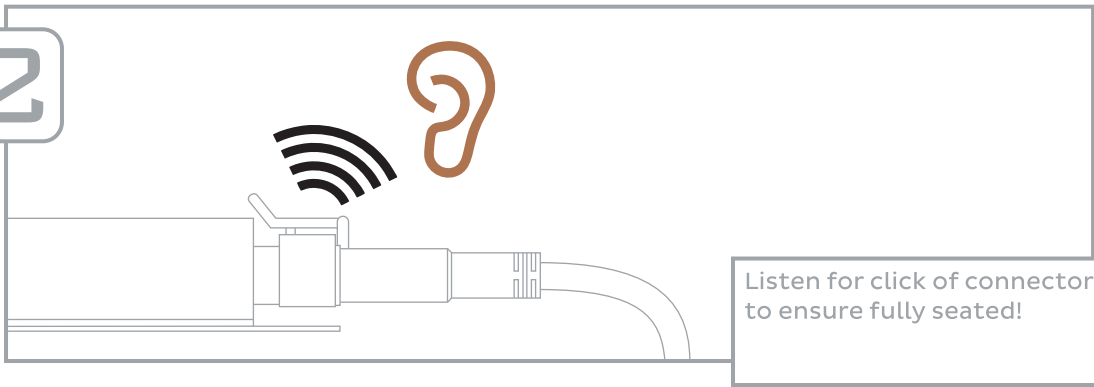

3

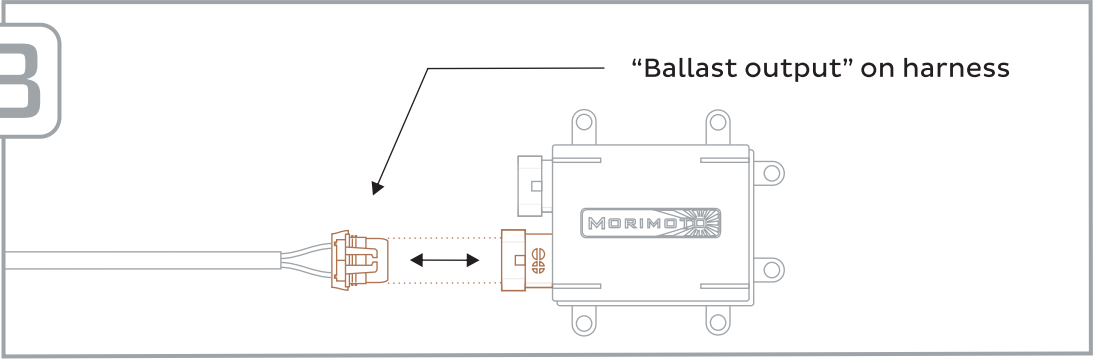

4

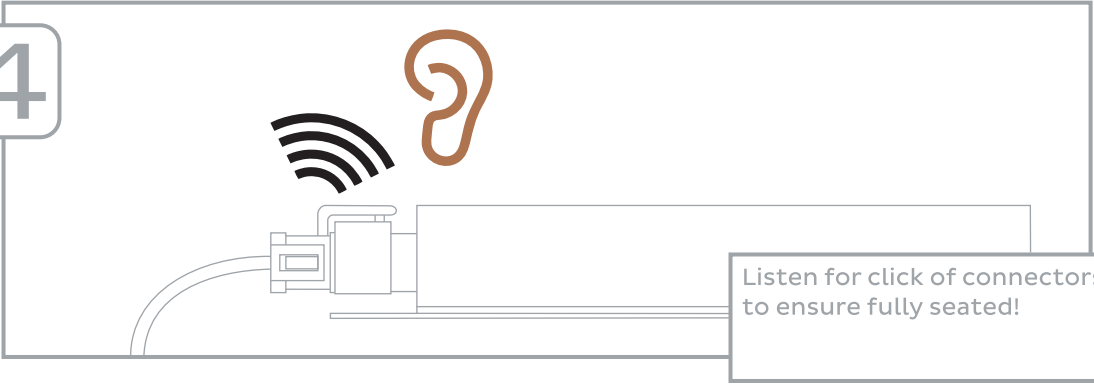

5

Recommended mounting:

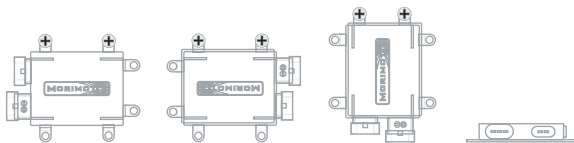

Do not mount ballast with connectors aimed upward!

-END-