

**IF YOUR ReadyLIFT PRODUCT IS MISSING A PART  
OR HAS A DAMAGED PART, PLEASE  
CONTACT CUSTOMER SERVICE DIRECTLY.**

**A NEW REPLACEMENT PART WILL BE SENT TO YOU IMMEDIATELY**

**(800)549-4620**

**MON-FRI 7AM-5PM PST**

**OR**

**EMAIL: INFO@ReadyLIFT.COM**

**WEBSITE: ReadyLIFT.COM**

**\*\*Please retain this document in your vehicle at all times\*\***

### **ReadyLIFT Limited Lifetime NO Fine Print Warranty**

**This unique product warranty proves our commitment to the quality and reliability of every product that ReadyLIFT manufactures. The ReadyLIFT warranty does not include shock absorbers.**

**The ReadyLIFT product warranty only extends to the original purchaser of any ReadyLIFT product, if it breaks, we will give you a new part. Warranty does not apply to discontinued parts**

Product purchased directly from ReadyLIFT has a 30 day return policy on uninstalled products from the date of purchase. Uninstalled product returns must be in the original ReadyLIFT packaging. Please call **800-549-4620** to get an RGA# for any return. Customer is responsible for shipping costs back to ReadyLIFT. **Returns without RGA# will be refused.** Contact ReadyLIFT directly about any potentially defective parts prior to removal from vehicle. If the part in question is deemed warrantable an RGA# will be assigned and can be returned for repair or replacement. Replacement parts required prior to warranty claim completion must be purchased. Upon receipt and verification of deemed warranty parts claim, a credit or refund can then be processed to complete warranty claim transaction.

ReadyLIFT products are **NOT** intended for off-road abuse. Any damage or failure as a result from off-road abuse voids the warranty of the ReadyLIFT product. ReadyLIFT is **NOT** responsible for any subsequent damages to any related vehicle parts due to misuse, abuse, improper installation, or lack of maintenance. Furthermore, ReadyLIFT reserves the right to change, modify or cancel this warranty without prior notice.

**[www.ReadyLIFT.com](http://www.ReadyLIFT.com)**

**Please read Instructions thoroughly and completely before beginning installation.  
Installation by a certified mechanic is recommended.**

**ReadyLIFT Suspension Inc. is NOT responsible for any damage or failure resulting from improper installation.**

**Safety Warning:** Suspension systems or components that enhance the on and off-road performance of your vehicle may cause it to handle differently than it did from the factory. Extreme care must be used to prevent loss of control or vehicle rollover during abrupt maneuvers. Always operate your vehicle at reduced speeds to ensure your ability to control your vehicle under all driving conditions. Failure to drive safely may result in serious injury or death to driver and passengers. Driver and passengers must ALWAYS wear your seat belts, avoid quick sharp turns and other sudden maneuvers. ReadyLIFT Suspension Inc. does not recommend the combined use of suspension lifts, body lifts, or other lifting devices. You should never operate your vehicle under the influence of alcohol or drugs. Constant maintenance is required to keep your vehicle safe. Thoroughly inspect your vehicle before and after every off-road use.

**Installation Warning:** All steps and procedures described in these instructions were performed while the vehicle was properly supported on a two post vehicle lift with safety jacks. Use caution during all disassembly and assembly steps to insure suspension components are not over extended causing damage to any vehicle components and parts included in this kit. Included instructions are guidelines only for recommended procedures and are not meant to be definitive. Installer is responsible to insure a safe and controllable vehicle after performing modifications.

ReadyLIFT Suspension Inc. recommends the use of an OE Service Manual for model/year of vehicle when disassembly and assembly of factory and related components. Unless otherwise specified, tighten all bolts and fasteners to standard torque specifications listed within the OE Service Manual, or as referenced in the torque specification list provided in these instructions.

Suspension components that use rubber or urethane bushings should be tightened with the vehicle at normal ride height. This will prevent premature wear or failure of the bushing and maintain ride comfort. Larger tire and wheel combinations may increase leverage on suspension, steering, and related components. Due to payload options and initial ride height variances, the amount of lift is a base figure. Final ride height dimensions may vary in accordance to original vehicle ride height. Always measure the vehicle ride height prior to beginning installation.

### Vehicle ride height chart

**Driver Front:  
Stock height**

**Lift installed**

**Driver Rear:  
Stock height**

**Lift installed**

**Pass. Front:  
Stock height**

**Lift installed**

**Pass. Rear:  
Stock height**

**Lift installed**

Bolt Size Millimeters	Torque Specs in FT/LB		Bolt Size SAE	Torque Specs in FT/LB	
	Metric Grade 8.8	Metric Grade 10.9		Grade 5	Grade 8
6mm	6	8	5/16	15	20
8mm	16	22	3/8	30	35
10mm	40	45	7/16	45	60
12mm	54	70	1/2	65	90
14mm	89	117	9/16	95	130
16mm	132	175	5/8	135	175
18mm	182	236	3/4	185	280

## Installation Instructions (69-3010 & 69-3015)



Raise and support vehicle frame on jack stands



Remove front wheels/tires



Disconnect ABS/brake bracket from upper control arm.



Disconnect dr/pass sway bar end links



Remove lower strut mounting bolts



Pry up ABS retaining clips from upper strut mounting nuts



Remove upper strut mounting nuts



Remove entire strut assembly from vehicle.

## Installation Instructions (69-3010 & 69-3015)

(Fig. 1) With the strut removed from the vehicle, place one of the plates onto the top of the strut. Be sure to align section "A" (non-slotted holes) with the stud

(Fig. 2) Failure to do this will result in the part breaking under load and possible damage to factory parts, voiding any ReadyLIFT® warranty.

(Fig. 3) Section "A" is also the tallest section of the plate

The following figures show the configuration for desired amount of lift.

(Fig. 4) Install the top plate, aligning position C to A on the bottom plate. **Lift=1.0"**

(Fig. 5) Install the top plate, aligning position B to A on the bottom plate. **Lift=1.25"**

(Fig. 6) Install the top plate, aligning position A to A on the bottom plate. **Lift=1.5"**

Figure 1



Figure 2

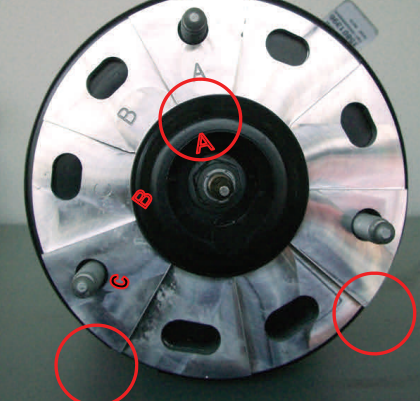
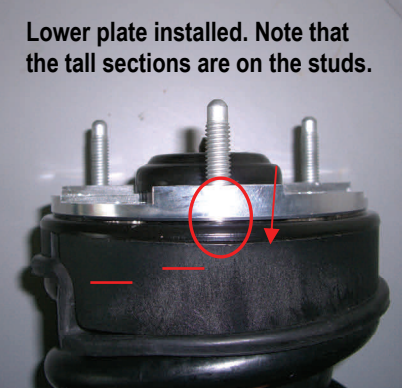

Figure 3



Lower plate installed. Note that the tall sections are on the studs.

Figure 4 A-C = 1" at the wheel



Figure 5 A-B = 1.25" at the wheel



Figure 6 A-A = 1.5" at the wheel

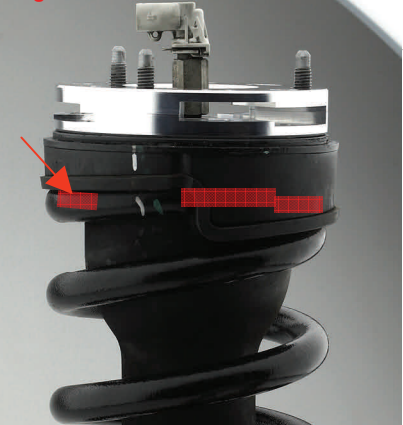

**Note:** (Fig. 4, 5 & 6) Shows the gaps between the spacer halves when installed, along with the stud length protruding through the spacers. Use the new provided mounting nuts on top and reuse factory bolts on the bottom to reattach the strut back into the factory position. Vehicles requiring 1.5" may need to separate the upper ball joint from the spindle in order to reinstall the extended strut spacer. If your vehicle is equipped with **Autoride**, make sure to reconnect the sensors. Re-attach upper stud wiring clips. **Note:** **69-3015** kits require the upper ball joint be disconnected to achieve the **2.25"** of lift.



Support suspension loosen upper ball joint nut



Strike spindle with hammer to loosen ball joint

## Installation Instructions (69-3010 & 69-3015)



Place spacer on strut top and reinstall loosely with new nuts



Install lower strut spacer and tighten,

**69-3010:** Reinstall strut into vehicle and attach top with new hardware and OE on the lower and reconnect sway bar end links and ABS/brake line bracket, tighten  
**69-3015:** Raise suspension with jack, reconnect upper ball joint, sway bar end link, ABS/brake line bracket and tighten. Tighten the upper strut mounting nuts and make sure the upper ABS line clips are out of harms way. Reinstall wheels/tires.

### **Rear Installation:**

Move to the rear of the vehicle with frame supported by jacks stands. Support axle with jack



Unclip ABS lines at upper trailing arm



Follow line up and unclip ABS lines at frame



**AUTORIDE ONLY:** Carefully pry arm off trailing arm bracket



Disconnect brake lines at top of differential

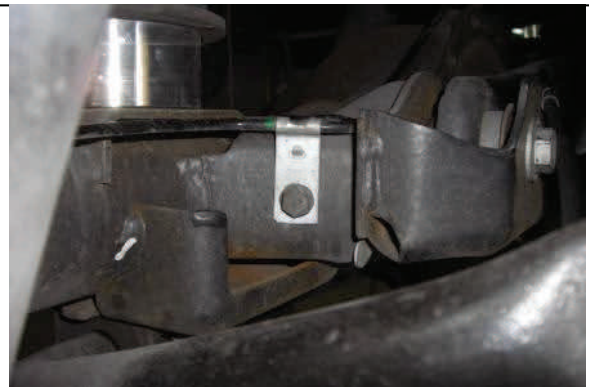

Unbolt dr/pass brake lines on axle

## Installation Instructions (69-3010 & 69-3015)



On the driver side frame unbolt e-brake hanger



Support axle with jack and disconnect sway bar end links



Disconnect Lower shock mounts

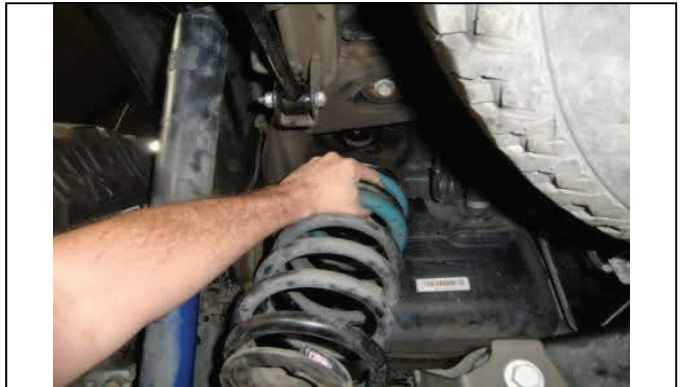

Carefully lower axle and remove coil springs and isolators



Place ReadyLIFT spacer on axle mount



Refit OE rubber isolator on top of billet spacer



Reinstall coil spring and seat on top of spacer, raise axle.

Reconnect rear shocks and sway bar end links, Reattach all brackets and ABS lines in their original locations and recheck all work. Replace wheels/tires lower vehicle and torque to spec. Test drive and have vehicle aligned.

## **Final Checks & Adjustments**

**Post Installation Warnings:** Once the vehicle is lowered to the ground, check all parts which have rubber or urethane components to insure proper torque. Torque wheels to factory specs. Move vehicle backwards and forwards a short distance to allow suspension components to adjust. Turn the front wheels completely left then right and verify adequate tire, wheel, brake line, and ABS wire clearance. Test and inspect steering, brake and suspension components for tightness and proper operation. Inspect brakes hoses and ABS lines for adequate slack at full extension. Failure to perform the post inspection checks may result in vehicle component damage and/or personal injury or death to driver and/or passengers. Test drive vehicle and re-check the torque of all fasteners and re-torque wheels on vehicle. Re-adjust headlamps.

**Vehicle Handling Warning:** Vehicles with larger tires and wheels will handle differently than stock vehicles. Take time to familiarize yourself with the handling of your vehicle.

### **Wheel Alignment/Headlamp Adjustment:**

**It is necessary to have a proper and professional wheel alignment performed by a certified alignment technician. Align the vehicle to factory specifications. It is recommended that your vehicle alignment be checked after any off-road driving. In addition to your vehicle alignment, for your safety and others, it is necessary to check and adjust your vehicle headlamps for proper aim and alignment**

### **Vehicle Re-Torque and Safety Inspection:**

Upon completion of all services and adjustments performed on your vehicle, and within 50 miles of driving, check to ensure all fasteners and hardware are properly torqued to specification as noted in the vehicles factory service manual or the torque chart included.

**[WWW.ReadyLIFT.com](http://WWW.ReadyLIFT.com)**

**ReadyLIFT Suspension Inc.  
7490 Commercial Way  
Henderson, NV 89011  
Phone: (702)410-2300  
Fax: (702)410-2794  
Toll Free: (800)549-4620  
Email: [Info@ReadyLIFT.com](mailto:Info@ReadyLIFT.com)**