

RACE
APPLICATION
ONLY

702

94-02 DODGE 5.9L 4" DUAL WITH HANGERS

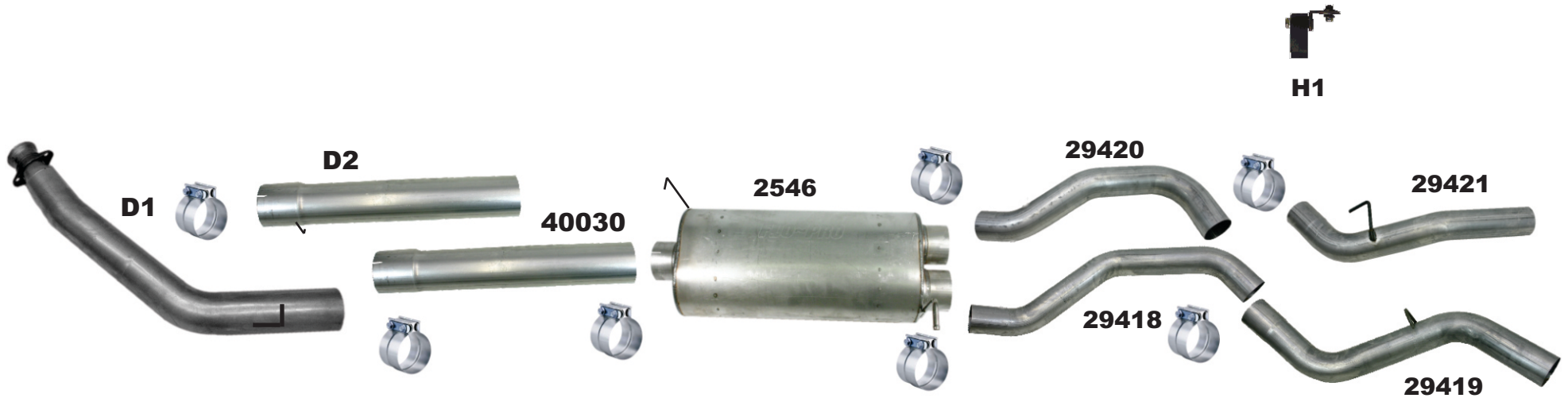

- | | |
|---------------------------------------|---------------------------------------|
| <input type="checkbox"/> 1-D1(4-5) | <input type="checkbox"/> 1-29419(3-5) |
| <input type="checkbox"/> 1-D2(4-4) | <input type="checkbox"/> 1-29420(3-6) |
| <input type="checkbox"/> 1-40030(1-2) | <input type="checkbox"/> 1-29421(3-6) |
| <input type="checkbox"/> 1-2546 | <input type="checkbox"/> 7-LJ400 |
| <input type="checkbox"/> 1-29418(3-5) | <input type="checkbox"/> 2-H1 |

FLO~PRO
PERFORMANCE EXHAUST

PICKED BY: _____



**WARNING: BEFORE YOUR BEGIN, VERIFY
THAT YOU RECEIVED THE RIGHT KIT &
EACH PART LISTED ON THE REVERSE PAGE
KIT #702**



1994-2002 DODGE, 4" DUAL(4WD ONLY)

NOTE: This system will NOT work on vehicles equipped with Brake proportional valves.

REMOVAL OF ORIGINAL SYSTEM

1. Starting at turbo, remove the two bolts from turbo flange; be sure to keep the bolts, as you will need them for installation of new system.
2. Cut exhaust pipe in two places; first cut the down pipe next to the transmission and second in front of the muffler. Spray the rubber hangers with WD-40 or Loosen-All and then pry hanger out of the rubber hanger and remove the factory exhaust from the truck. **(Note: a sawzall or hacksaw is the preferred method of cutting exhaust)**. Be sure to keep all the rubber hangers, as some of these will be used in the installation of the new system).

INSTALLATION INSTRUCTIONS

1. Install #D-1 pipe using stock bolts. Snug the flange down with bolts until it will hold pipe but pipe can still be moved.
2. Install pipe #D-2 be sure to insert rod into hanger.
3. Temporarily hang muffler in factory rubber hangers.
4. Now that the muffler is hung in truck measure from rear of pipe #D-2 to the front of muffler, this is the cut length of pipe #40030. **(Note: be sure to allow for tubing connections approx. 4: also make sure to cut pipe #40030 from the non-expanded end)**.
5. Install pipe #40030 and muffler on factory rubber hangers. Put on the clamps, snug the clamps down so they will hold pipe and muffler but the pipes and muffler can still be moved with some effort.
6. Install tail pipe #29420 into the right side outlet of muffler and out on the right side of truck.
7. Install tail pipe #29421 on to pipe #29420. **(Note: hanger is bolted from inside the frame using factory hole in the frame above the hanger on pipe #29421)**.
8. Install pipe #29418 into left outlet of muffler.
9. Install tail pipe #29419 on to pipe #29418. **(Note: Once connected the tailpipe assembly should run out between the shock and leafspring and the hanger is bolted from inside the frame using the factory hole in frame above the hanger on pipe #29419)**
10. Install all the clamps on tail pipes. Snug the clamps down so they will hold the pipes but the pipes can still be moved with some effort.
11. **Check for clearances, i.e. brake lines may have to be moved, or e-brake cables as well as axle vent tube.** Also check to make sure that the exit of tail pipes is level with truck.
12. Starting at #D-1, tighten turbo flange bolts then starting at front clamp, work your way to the back connection on right side of truck, tightening the clamps as you go. Now tighten the left side. **(Note: a mig weld should be applied to clamp connections for added security)**.

Note: Universal converter adapter kit #4000 is required on all converter-equipped models.

www.flopro.com

Technical Support: 1 800 762 4286 or email, techsupport@flopro.com