



DOMETIC CORPORATION  
 1120 North Main Street, Elkhart, IN 46514  
 Please Visit: WWW.DOMETIC.COM



LITERATURE NUMBER 15000

**Rooftop Air Conditioner  
 for Recreational Vehicles**

**Non-Ducted Models**  
 AC-1351 & AC-1501

•Installation •Operation •Maintenance

Revision A, 2/20/19

This air conditioner design has been certified by the Canadian Standards Association for installation in recreation vehicles.

**SERVICE CALLS & QUESTIONS**

Location and phone numbers of qualified Service Centers can be found at our website <http://www.dometic.com>



**WARNING:** It is important that this installation manual is read and understood before installation. The unit must be installed by a qualified service technician. Failure to properly install the unit or attempting to modify it in any way can be extremely hazardous and may result in property damage and personal injury and will void the warranty.

**BEFORE INSTALLATION**

Ensure that the installation instructions have been properly read and understood.  
 Installation must conform to Local wiring codes and regulations or, in the absence of local codes, the Standard on Recreational Vehicles, NFPA 1192. and National Electrical Code NFPA 70.  
 DO NOT attempt to modify or add components to the installation procedure.  
 This equipment must only be serviced by a licensed refrigeration mechanic to maintain warranty coverage.  
 If your installation varies from the method outlined please contact Dometic for specialty advice.



**Dometic will not be held responsible for problems relating to incorrect or improper installation methods.**

**GENERAL INFORMATION**

**I. PURPOSE**

This Dometic AirCommand air conditioning unit is designed for installation on the roof of a recreational vehicle to provide cooling with AC-1351 models and cooling/heating with AC-1501 models.  
 -The roof must be capable of supporting the weight of the unit which is 86lbs (39Kg).  
 -The absolute minimum thickness of the roof must not be less than 1 inch (25mm).  
 -The maximum thickness of the roof must not exceed 5 inches (125mm).  
 -Trimming of the ductwork and/or bolts may be necessary depending on the roof thickness  
 It is important that the unit is installed properly and according to the recommended guidelines.

**II. ENSURING EFFECTIVE OPERATION**

The effectiveness of the air conditioner is dependent on several factors e.g. size and heat load of the vehicle. When an Dometic unit is installed, Dometic assumes that the vehicle is well insulated with 1 inch (25mm) foam minimum in all walls and roof, that the windows are of moderate size (preferably double glazed) and the roof vents are airtight when closed. Other methods of reducing heat load include:  
 -Closing all doors, hatches, windows and blinds  
 -Position the vehicle so if porch is used, it will face the sun and protect the windows from direct radiation.  
 -Turning off appliances that might increase the heat load  
 -Ensuring the vehicle is parked in a shaded position.  
 In periods of extreme high temperature it is recommended to start the air conditioner earlier in the morning to greatly improve its ability to cope with the expected high heat load.

**III. CONDENSATION**

In areas of high humidity, the humid air within the RV will cause "sweating" or condensation in parts of the unit as the humid warm air contacts the colder air discharge system. If this occurs please ensure the following:  
 -Closing all doors, hatches, windows and blinds to limit the ingress of warm humid air  
 - Avoid running the inside fan on LOW or AUTO in such conditions. Running the fan on HI fan speed will result in higher airflow and reduce the tendency to have condensation form.

# INSTALLATION PARTS LIST

## MAIN COMPONENTS

- 1) Dometic AirCommand Rooftop Air conditioner
- 2) Roof Seal Gasket 2 Pcs
- 3) Adapter
- 4) Extension Duct
- 5) Brace Assembly
- 6) Plenum
- 7) Plenum Filters x2

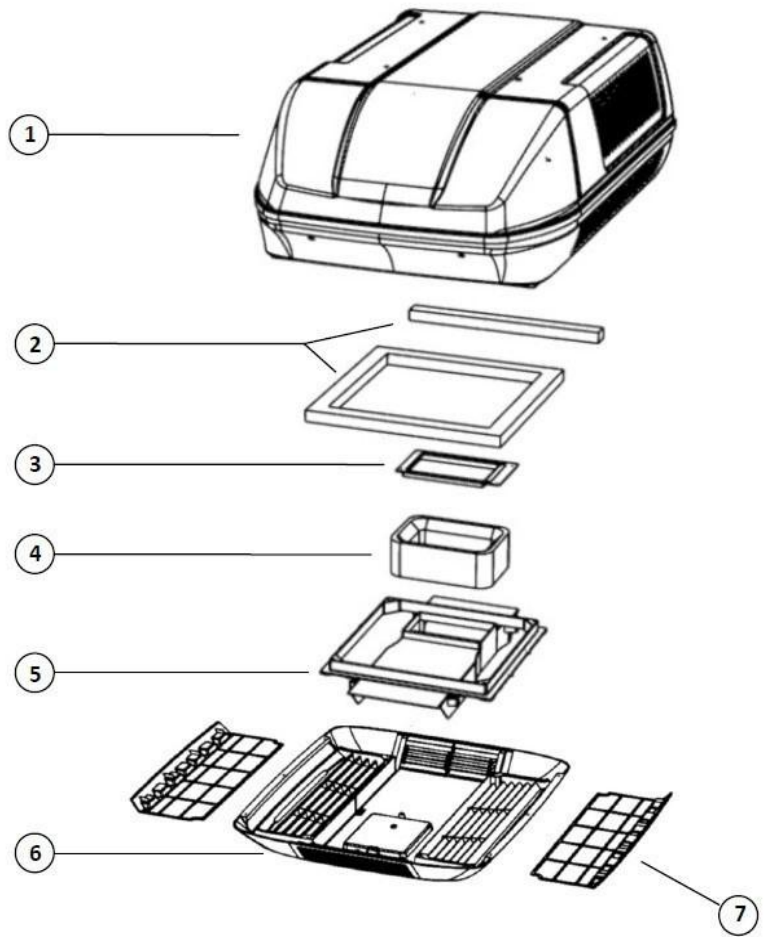

## FITTINGS & FIXTURES

- 8) M8 Bolts x 4
- 9) Hold Down Bars x 4
- 10) Plenum Cover Screws x 4
- 11) Self Tapping Screws x 6

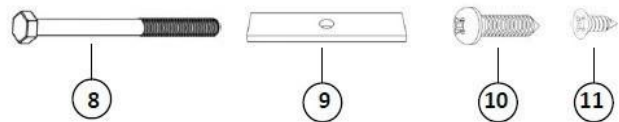

## INSTALLATION POSITION

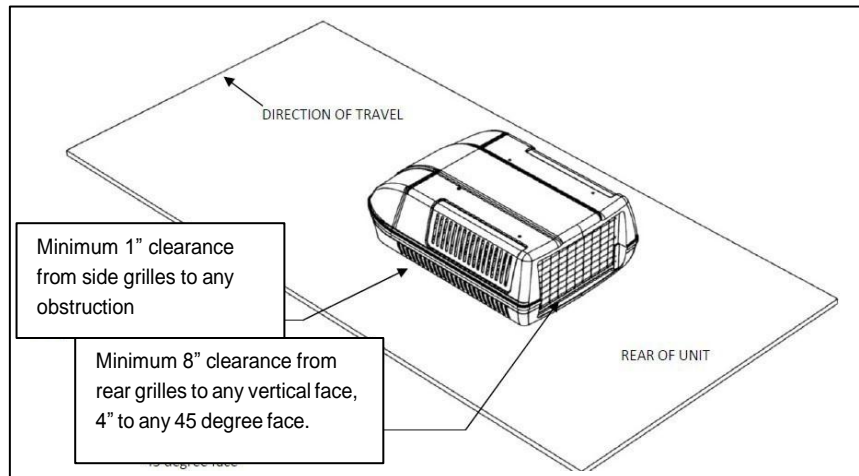

## Unit Installation (Non-Ducted)

Before beginning, mark out the position of the unit considering the following important requirements:

- The air conditioner should be situated as centrally as possible on the vehicle, to ensure even air distribution.
- The front of the unit **MUST** face the direction of travel; failure to follow this instruction will result in damage to the condenser fans.
- If the vehicle is over 23' in length, or has an unusually high heat load (see General Operating Information section regarding expectations about insulation etc.), Dometic recommends 2 or more units to cool effectively.
- When considering the installation position remember to check for clearance around the plenum inside the vehicle.
- Avoid an installation position where a bulkhead, cupboard or light fitting could interfere with the discharge air flow from the plenum.



### CAUTION

It is important that the unit is never more than 5° from the horizontal and the rear of the unit should never be higher than the front.

- Contact Dometic if your installation differs significantly.

## ASSESS ROOF STRENGTH

- The roof members **MUST** be strong enough to support the weight of the unit 99 lbs (45kg) without any roof deflection that will cause "pooling" of water around the unit. Contact your RV manufacturer to confirm the max load the roof is able to handle. If in any doubt consider the use of an external "H" frame.

- If the roof does not have an existing hole one must be cut. Cut from the roof then use the roof hole as a guide to cut through the ceiling. Contact your RV manufacturer for the best method to cut through the roof.

- The square hole in the roof (14" x 14") **MUST** be boxed up with minimum 3/4 inch square timber to provide a structure strong enough to withstand the compression of the installation bolts. This is also to ensure that air is not drawn from the roof cavity (Fig 3 & 4). Remember to leave access for wiring.

- Longitudinals **MUST** be fixed securely to the transverse roof members to transfer load (see Fig 3).

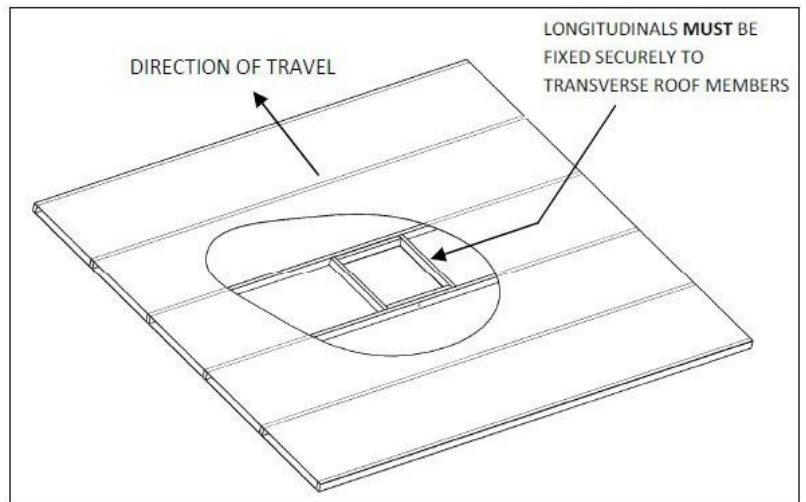

Fig 3: Shows an ideal roof structure with strong longitudinals and a 14' hole boxed

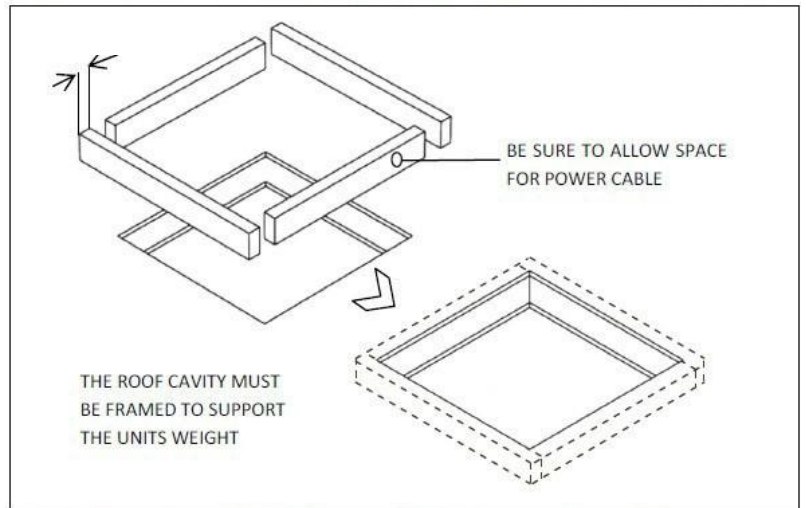

Fig 4: The roof cavity **MUST** be boxed with timber to provide a solid structure



### WARNING

There may be electrical wiring located between the roof and ceiling. Ensure that power is properly disconnected at the supply (mains and/or battery). Failure to do so may result in personal injury or death

**TIP:** Always use crawl boards across the roof to avoid damage

## POSITION UNIT ON ROOF

- Remove the air conditioner from the carton.
- Position the unit over the gasket so that the corners of the square hole in the RV roof line up with the corners of the square hole underneath the air conditioner (Fig 6). **TIP:** Have one person inside the RV looking through the hole while the other is on the roof adjusting the position of the unit.



## CAUTION

The unit weights approximately 86lbs (39kg). Ensure a two person lift or use a mechanical hoist to avoid the risk of injury.

- DO NOT slide the unit on the roof, this may damage the gasket and result in leaks.
- Four M8 mounting holes on the chassis underneath the air conditioner will line up with the corners of the square roof hole (Fig 7).

## ATTACH ADAPTER TO UNIT

- Screw adapter to the underside of unit with the 4 screws provided (this step can also be done before the unit is positioned on the roof but be careful not to damage while fitting)
- The adapter will only fit one way, be careful to ensure adapter is positioned correctly (Fig 8) and avoid affixing back to front.



## WARNING

Ensure that power is properly disconnected at the supply (mains and/or battery). Failure to do so may result in damage to the unit and personal injury or death.

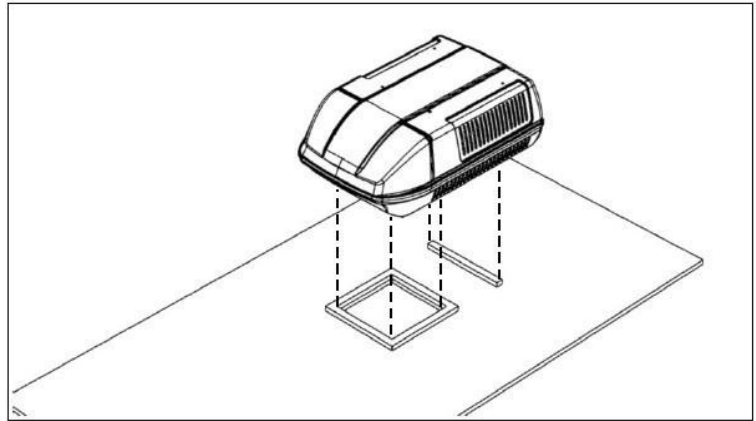

Fig 6- Position the unit over the roof gasket and set down gently.

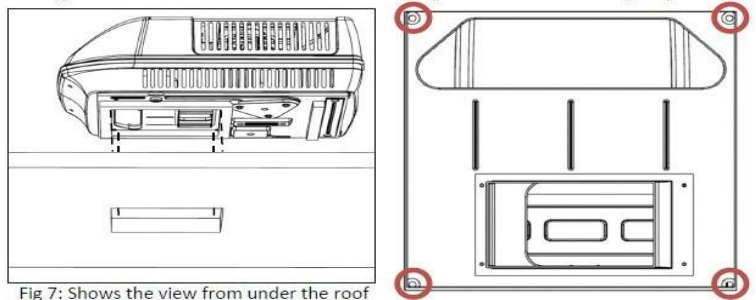

Fig 7: Shows the view from under the roof

Position the unit so the 4 mounting holes (circled) line up with the corners.

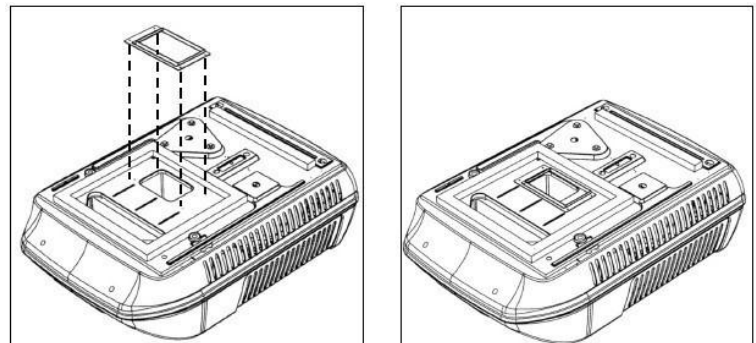

Fig 8: Shows positioning of adapter to be attached to underside of unit. Ensure adapter is mounted the correct way, screw holes will not line up if attached out of phase.

## CONNECT ELECTRICAL SUPPLY

Installation must conform to local wiring codes and regulations or, in the absence of local codes, the Standard on Recreational Vehicles, NFPA 1192. and National Electrical Code NFPA 70.

- Connect AC power supply to wire leads from unit

Note:

Brown wire from rooftop unit to Black or Red from customer – AC Hot  
 Blue wire from rooftop unit to White wire from customer – AC Common  
 Yellow/Green wire from rooftop unit to Green wire from customer - Ground

Note: Dometic strongly recommends the use of the Molex connector described on the next page.



# COC-1 Self Contained Power Connector Installation Instructions For 2 Wire Cable With Ground Applications

The 2-circuit-with-ground connectors will splice non-metallic-sheathed cable in the following wire ranges and types:

Self Contained Connector -  
2 Circuit with ground for Solid Wire

Wire Range AWG	Order No.	Optional Hand Tool	Optional Bench Mount Tool	Optional Bench Arbor Press	Housing Color
12-14	19045-1000 (COC-1)	19285-0074	N/A	64006-0200	White

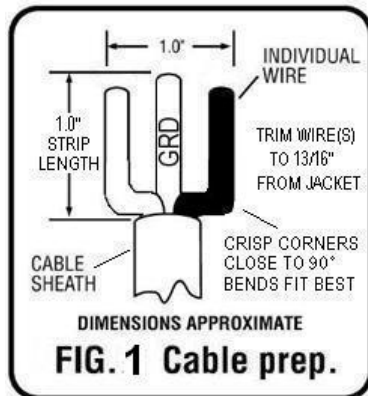

Reference Information  
UL File Number: E182087,  
CSA File Number: LR18689-C53  
NEC Article: 550, 551, and 545  
HUD Section: 3280.801  
Current: 20A, Voltage: 300V

## Installation Procedure:

- Carefully strip and prepare the wires to the configuration as shown in Figure 1 using helpful hints shown in photographs of Figure 2.
- Hold the clear strain relief cover with bottom facing upward as shown in Figure 3.
- Lay wire into locator slots, making sure the black wire is placed into the polarization slot as shown in Figure 3.
- Press the cable sheath into the integral strain relief slot as shown in Figure 3. Trimming of ground wire and possibly others will be necessary. Wires must not extend beyond the locators as shown in Figure 4!
- While holding the strain relief cover, position the housing's hinge posts into the hinge slots and press down until both lock into place as shown in Figure 4.
- Close the strain relief cover and housing by hand. Place the connector assembly into Molex tool (preferred) as shown in Figure 5. Squeeze the tool until the connector bottoms out and the locking latches engage on both sides. OR alternately, squeeze the top and bottom closed with tongue and groove pliers as shown in Figure 5.1. Pliers must be a minimum of 10" long. Squeeze firmly on both sides, squarely across the connector between ribs A and B to ensure wires seat completely into slots.
- Inspect the connector to ensure the wires have been properly engaged into the housing assembly contacts. A properly terminated wire is fully seated into its proper slots with no significant bow of the cover. If the wires extend past the insulations tops, the wires must be re-terminated with a NEW CONNECTOR. Once the cover has been closed the connector cannot be re-used. Failure to comply with this procedure may result in the failure of the connector.
- Mating and un-mating the completed connector is illustrated in Figure 6.

FIG. 2

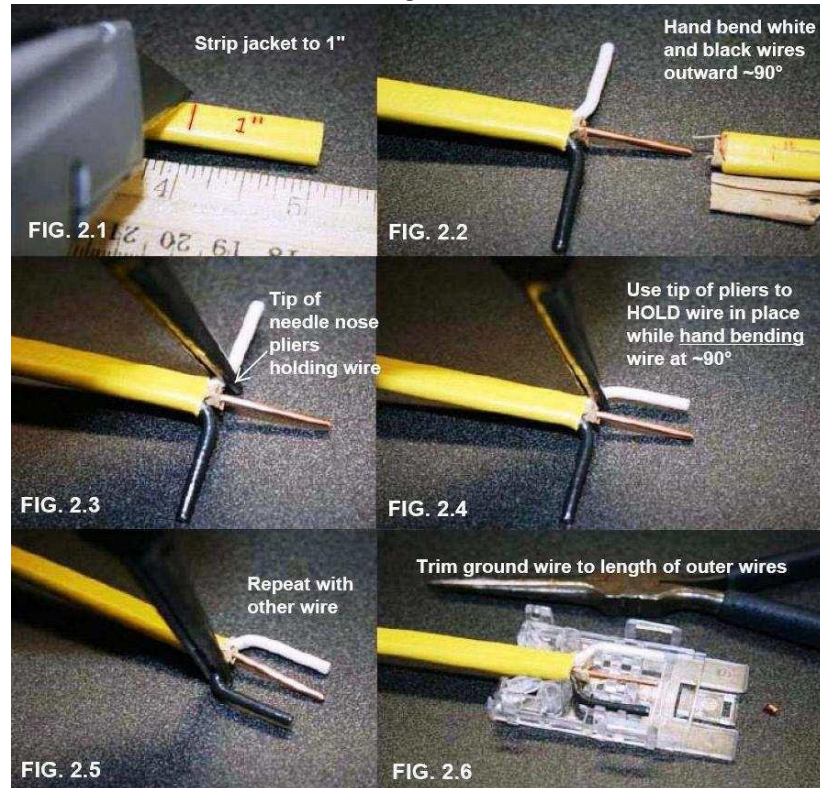

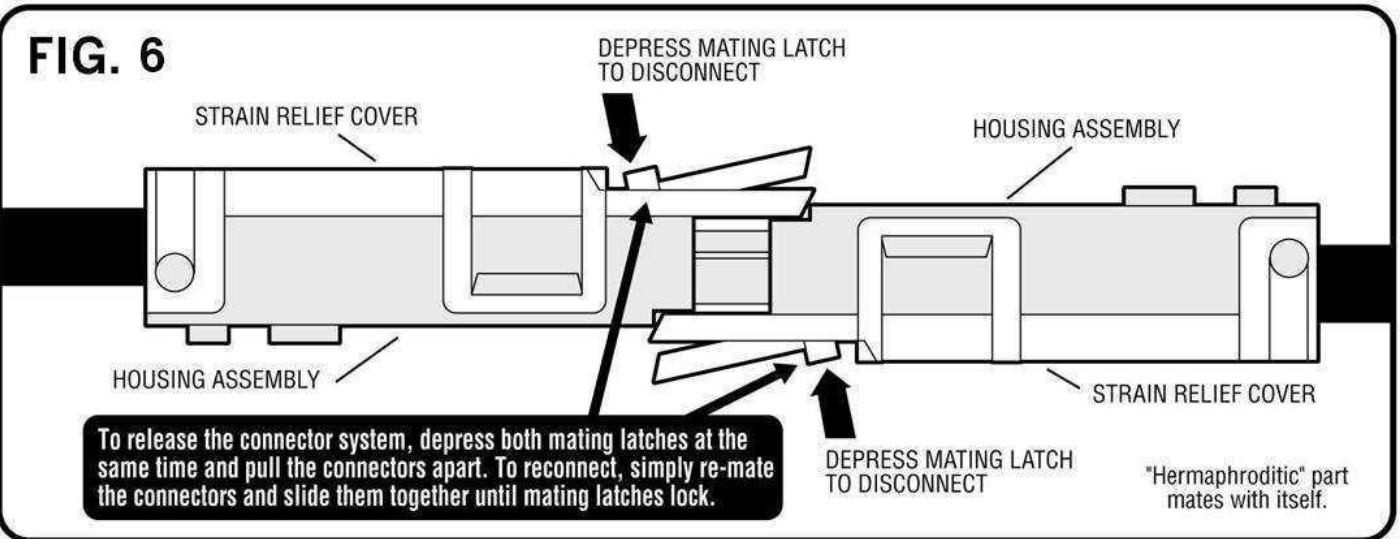
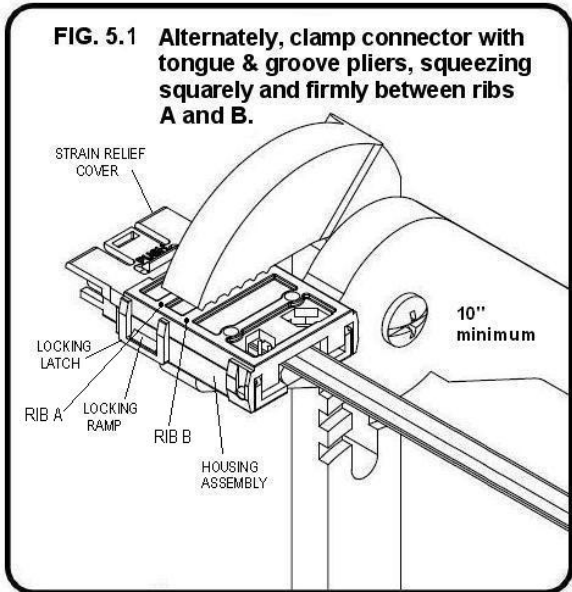
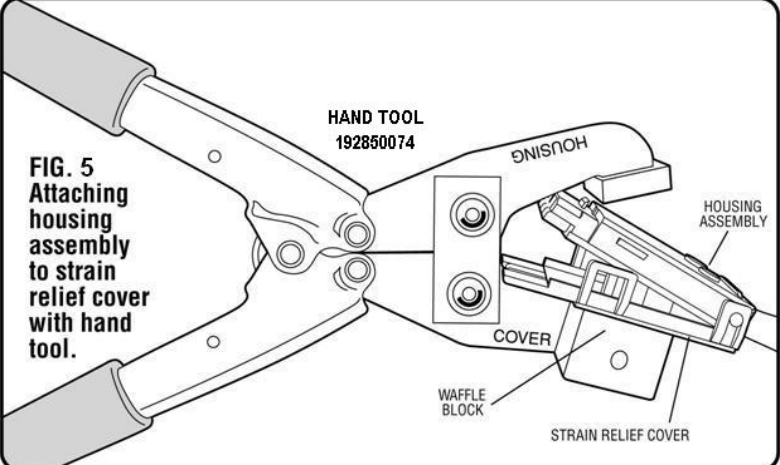
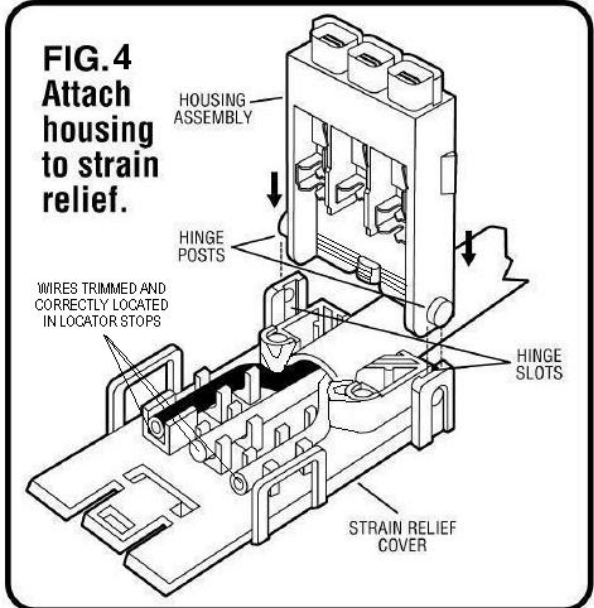
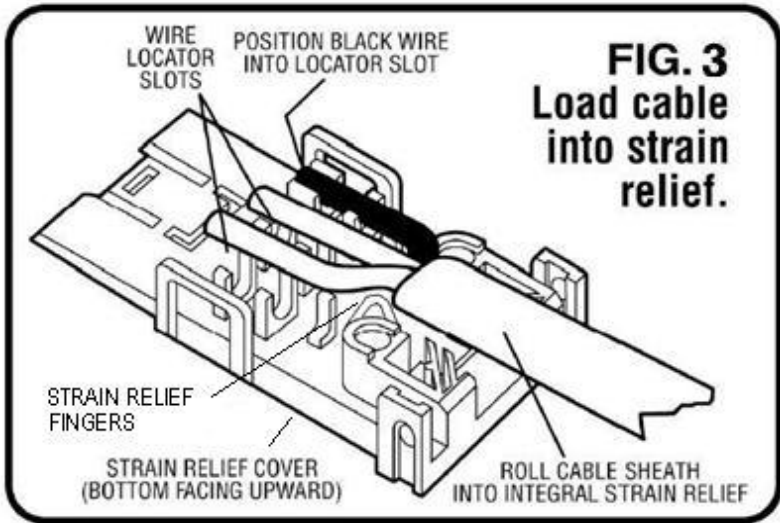

## ASSESS ROOF THICKNESS

- Measure the roof thickness and consult the table across to check if adjustments to the hold down bolt and duct length are required.

 **Failure to cut the duct properly can result in an incorrect seal which will adversely affect the units performance**

Roof Thickness - Inch (mm) – Include ‘H’ frame if used.	Duct length required – Inch (mm)	Hold down bolt length required – Inch (mm)
4.92 (125)	5.71 (145) as supplied	As supplied
3.94 (100)	4.72 (120) - Cut .98 (25)	As supplied
3.15 (80)	3.94 (100) – Cut 1.77 (45)	As supplied
2.36 (60)	3.15 (80) – Cut 2.56 (65)	Cut 1.97 (50)
1.57 (40)	2.36 (60) – Cut 3.35 (85)	Cut 2.76 (70)
1.0 (25) (absolute minimum)	1.57 (40) – Cut 3.94 (100)	Cut 3.35 (85)

## ASSEMBLE DUCT

- Thread a hold down bar onto the M8 bolt and push the bolt almost all the way into the hole in each corner of the brace (Fig 9)
- Leave a .40 inch gap between the hold down bar and the recess in the plastic brace. This will allow for easier engagement with the four corresponding threaded holes in the unit.
- Turn the assembly over and add the extension duct to the top of the assembly (Fig 11).
- Take care to avoid tearing or ripping the duct apart.

 **When attaching the duct to the unit take care to ensure it forms a tight, unbroken seal that doesn't allow discharge air to escape.**

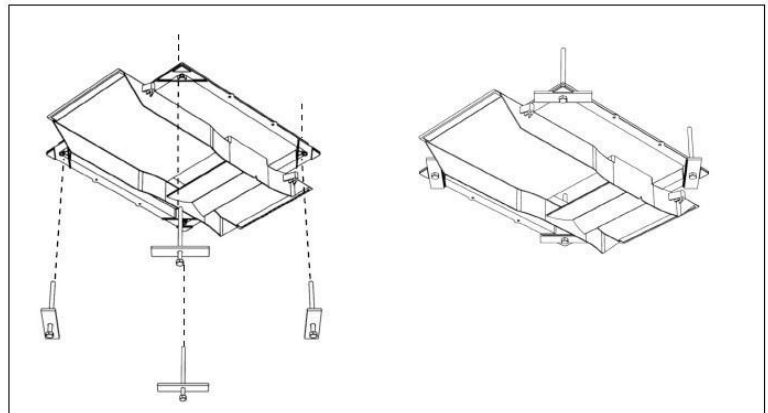

Fig 9: Insert the four M8 bolts and hold down bars into the corners of the brace

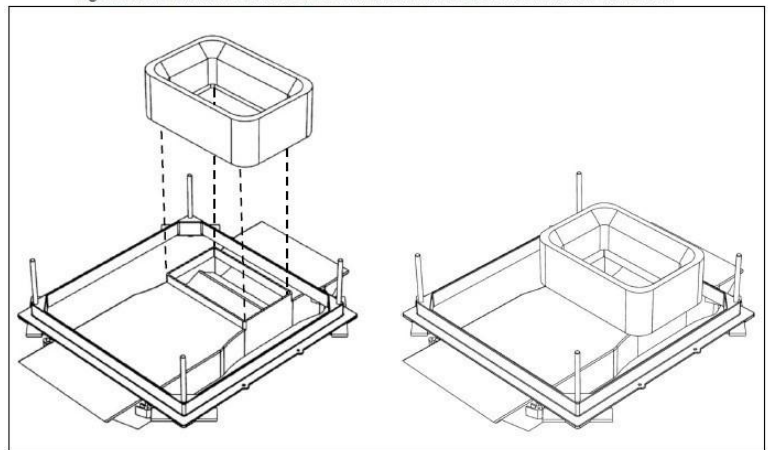

Fig 10: Fit the extension duct onto the brace assembly ensuring a tight, sealed fit



## ATTACH DUCT TO UNIT

- Raise the brace assembly and slip the extension duct over the outside diameter of the adapter underneath the rooftop unit. (Fig 11-12).



**When attaching the duct to the unit take care to ensure it forms a tight, unbroken seal that doesn't allow discharge air to escape.**

- Engage and tighten the four M8 bolts with the threaded inserts in the rooftop unit.
- Recommended tightening torque of the bolts is 7 N.m (5.2 lb-ft). As a rough guide the bolts should be tightened so that the unit compresses the roof seal gasket to approximately half its height.
- As the bolts are tightened ensure that the hold down bars slot into their recesses in the brace (Fig 12).

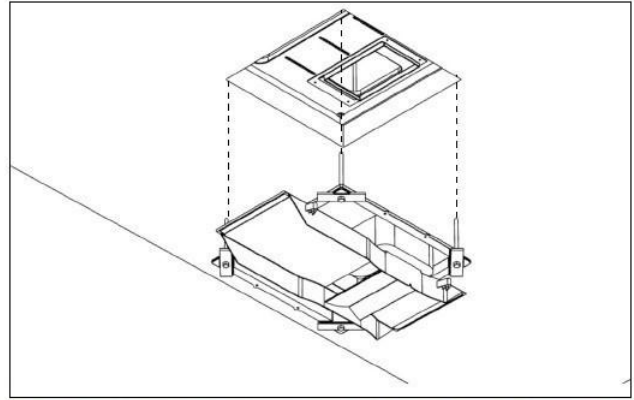

Fig 11: Raise the duct assembly up to the roof hole, ensuring the paper extension duct work forms a tight fit around the spigot underneath the unit.

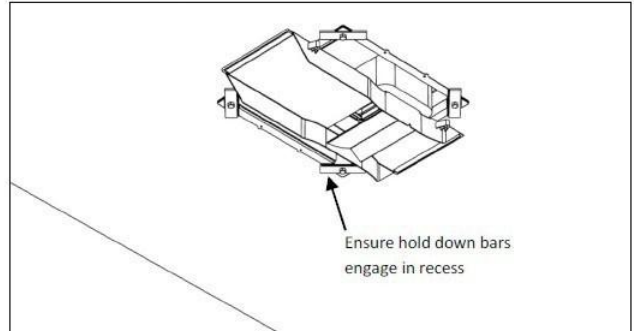
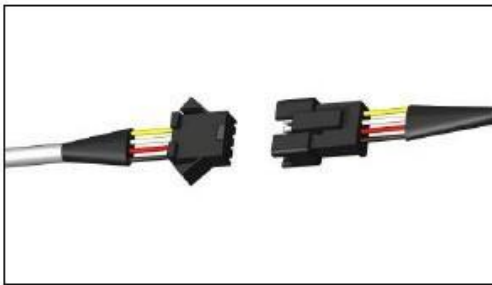

Fig 12: Then engage the four M8 bolts, taking care to ensure the hold down bars slot into their recesses

## ATTACH PLENUM COVER

- Connect the main cover of the plenum to the duct by attaching the blue suspension cord to the lug on the inside of the cover (Fig 13). Reach into the unit, grab the control cable plug and pull down to -This will allow you to use two hands to connect the control cable (see Fig 14).
- Connect the key pad control cables together (see below). Be sure that the plug joins the corresponding wire colors together (yellow to yellow, red to red etc.)



**Failure to properly plug the control cables together correctly will result in loss of power to display.**

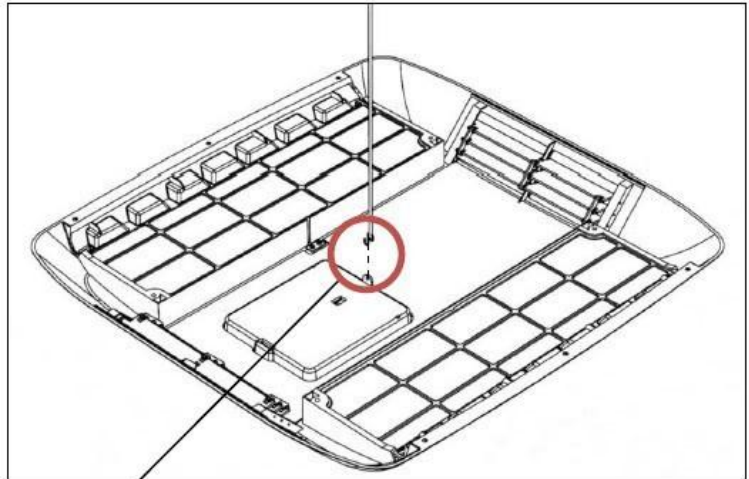
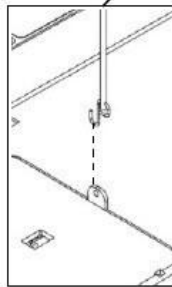

Fig 13: Shows the positioning of the lug inside the plenum cover



Pull the suspension cord down from inside the unit and hook it through the lug shown inside the plenum housing. This will allow two free hands to connect the control cables together.



## ATTACH PLENUM COVER

- Secure the main plenum cover to the duct assembly with the 4 screws provided (Fig 15).

**TIP:** It is important that these screws are not over tightened otherwise the plenum may crack.

- Remove the filter elements by pulling them out of the plenum, and use the six self-tapping counter sunk screws to secure the covers edges to the vehicle ceiling (Fig 16). In some instances a very small pilot hole may need to be drilled to guide the screws into place.

- Replace the return air filters by sliding them into the plenum until they click into place

-Your installation is now complete.

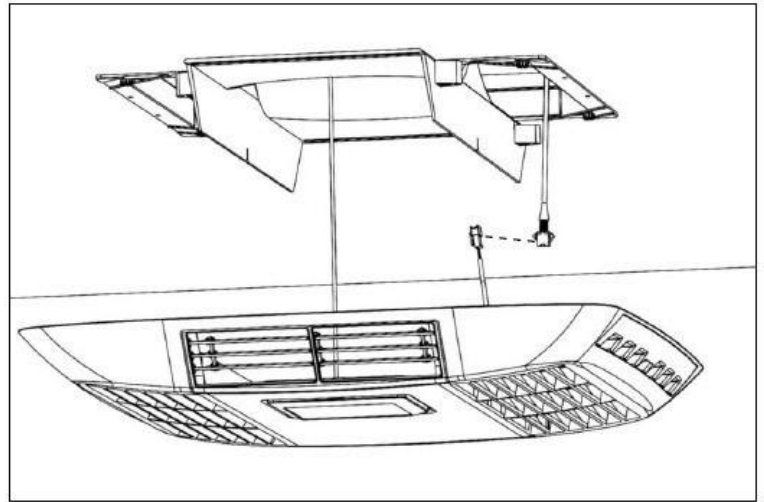

Fig 14: Attaching the suspension cord will allow two hands free to plug in the control cable and affix the plenum

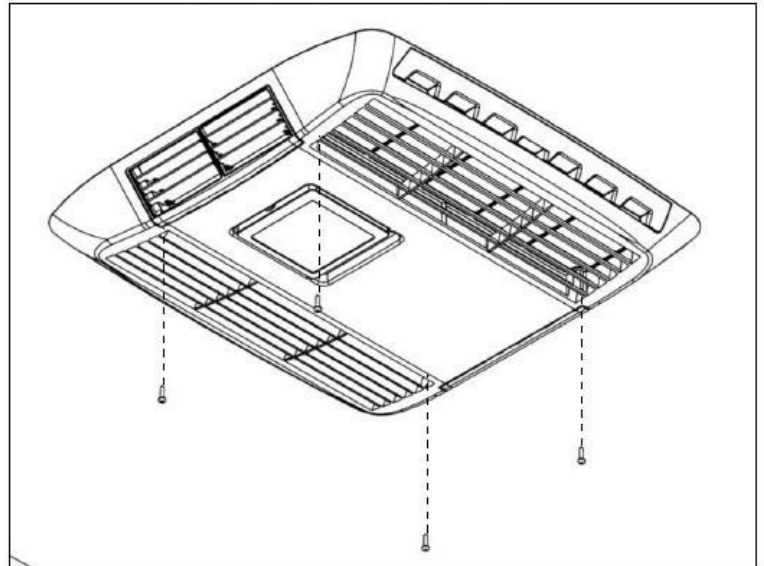

Fig 15: Secure the main plenum cover to the duct assembly with the four screws provided

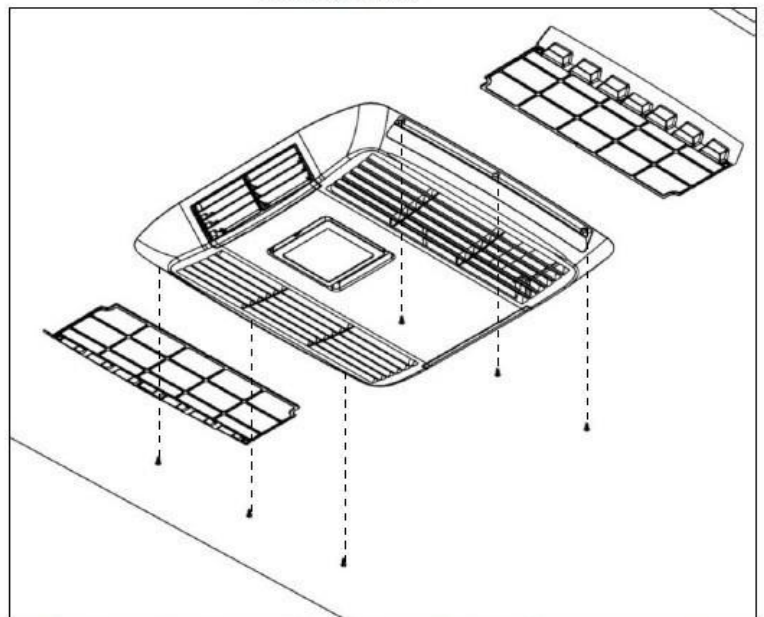

Fig 16: Remove the plenum filters and use the six self-tapping screws to ure the plenum over to the ceiling of the caravan. Be sure not to over tighten.

## INSTALLATION IS NOW COMPLETE

## VERIFYING NORMAL OPERATION

1. Turn the power on at the circuit breaker
2. Press the ON/OFF button and press the MODE button to select FAN
3. Cycle through the LO, MED and HIGH fan speeds checking that all speeds run.
4. Set mode to COOL, adjust temp via up/down buttons to approx. 6°F (3°C) **less** than the display temp (ie. Room temp) compressor will start within three minutes.
5. Set mode to HEAT, similarly set temp to approx. 6°F (3°C) **above** display temp. Compressor will start within three minutes.

After a few minutes the fan will start and warm air will be apparent.

**Note:** Regardless of the mode selected there will always be at least a 3 minute delay before the compressor starts.

## MAINTENANCE

### I. Plenum Filters

The plenum filters are the only parts that require routine maintenance.

They must be cleaned periodically to ensure that they do not become clogged with dust and other particles and not covered by Warranty.

To clean the two plenum filters, first remove them both from the plenum by pulling them out of the assembly.

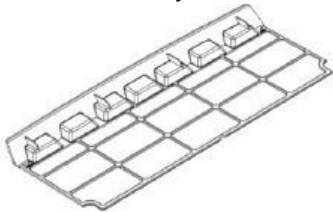

Fig 17 shows the plenum filter when removed.

The state of the filters can be ascertained from its appearance, the filters are translucent, and if they appear clogged then they should be cleaned. Generally the filters can be cleaned sufficiently by tapping them together to shake loose the dust and particles trapped inside.



### **WARNING**

**Airborne particles can pose a health risk, particularly to young children and the elderly. Ensure that filters are cleaned in a safe and well ventilated area.**

If a more thorough cleaning is required then the filters can be washed out using warm soapy water. Care must be taken to avoid ripping the fabric. The filters should be cleaned every two weeks or more when in use. Prolonged use, higher concentrations of airborne particles, and various other factors may result in the filters needing to be cleaned more often. Replacement filters can be ordered directly from Dometic.

### II. Mounting Bolts

Dometic suggests that the hold down bolts are initially checked for tightness within the first 3 months of installation, and thereafter every 12 months if the vehicle is in constant use.

### III. Storage

The air conditioner should be run on a routine basis to ensure the components remain in working order.

If the vehicle is in storage or is to remain unoccupied for an extended length of time it is recommended that the air conditioner is allowed to run uninterrupted for 20-30min once every six months.

## GENERAL SPECIFICATIONS

### Air – Conditioner

Height - 12.8 inch (325mm)  
 Width – 26.6 inch (675mm)  
 Length - 38.4 inch (975mm)  
 Weight – 99lb (45kg)

### Air Discharge Plenum

Height - 2.6 inch (65mm)  
 Width - 21.0 inch (535mm)  
 Length - 21.8 inch (555mm)  
 Weight – 1.1 lb (2.4kg)

### AC Description

13.5K Non-Ducted AC – White  
 13.5K Non-Ducted AC – Black  
 15K Non-Ducted AC – White  
 15K Non-Ducted AC – Black

### Model Number

AC-1351W  
 AC-1351B  
 AC-1501W  
 AC-1501B

	Model 13500	Model 15000
Electrical Rating:	115V, 60Hz	115V, 60Hz
Electrical Rating:	13,500 BTU/Hr	15,000 BTU/Hr
Nominal Heating Capacity:	n/a	15,000 BTU/Hr
F.L.A. Cooling:	12.5 A	13.0 A
F.L.A. Heating:	n/a	13.0 A
Locked Rotor Amps:	63 A	63 A
Refrigerant:	R410A	R410A
Refrigerant:	18 Oz (510 g)	24 Oz (670 g)
Total Installed Weight:	84 lb (38 kg)	86 lb (39 kg)

## OPERATING INSTRUCTIONS

- Turn the unit on by pressing the ON/OFF button once.
- Press the MODE button to cycle through the five mode selections: COOL, FAN, HEAT, DRY, AUTO Cool/Heat modes.

### - MODE – COOL

- Cycle mode pushbutton to highlight COOL.
- You may select HIGH, MED, LOW, or AUTO fan speeds by pressing the fan pushbutton. It is recommended that you choose Auto.
- Now select the desired room temperature (herein referred to as SETPOINT) by pressing the TEMP up or down pushbuttons. The readout will flash the setpoint temperature. Keep pressing the pushbutton until it flashes your desired set point. In approx. 5 seconds the display will resume reading the actual room temperature. The compressor will have a delayed start usually 3 minutes before unit starts to cool.

Note: Any interruption to the power supply will cause the unit to delay compressor start up

### - MODE – FAN

- For simply re-circulating air, choose the FAN mode. Choose any of the three fan speeds by pressing FAN button. Note: Temperature pushbuttons are invalid in FAN mode.

### - MODE - HEAT

- To heat, press MODE pushbutton to highlight HEAT.
- Select desired set point temperature by pressing TEMP up or down pushbuttons. It is recommended that the AUTO fan speed be selected.
- After the delay, the compressor will start. Usually the fan will stop and will not re-energize until the heat exchanger has warmed and then the fan will start to blow warm air.



Thermostat control module. A “cool only” model (AC-1351) will not have the furnace pushbutton on the display.

## OPERATING INSTRUCTIONS – Continued

### MODE - DRY

- The DRY mode is used when the room temperature is close to comfortable but you wish to dehumidify.
- Press MODE pushbutton to highlight DRY.
- Set the temperature to desired set point. Note: the fan speed is locked in LOW.
- The compressor will cycle on and off at approximate intervals of 6 minutes to extract moisture from the air.

### MODE – AUTO COOL/HEAT

- This mode has an outdoor defrost mode (indicated by a flashing HEAT LED). During the outdoor defrost cycle, the MODE pushbutton is inactive.

### SLEEP FUNCTION

- With the unit operating in heat or cool mode, press sleep pushbutton to highlight the sleep light. The unit over the next hour will automatically raise the set point by 2°F. Conversely in heat mode, the set point will be lowered 2°F.

### TIMER FUNCTION

- The timer may be used to turn off the unit in the future (up to 24 hours) OR the timer may be used to turn on the unit up to 24 hours in the future.
- Press TIMER pushbutton once and the display will flash. Within 3 seconds, press the timer pushbutton until you have set desired time into the future to turn unit off. A subsequent press of the timer pushbutton will allow the time to start the unit to be programmed.

### LOCK FUNCTION (key symbol)

- This provides a means of locking in the mode and fan settings. To lock, press Temp Down pushbutton simultaneously with MODE pushbutton. Hold for 3 seconds and the lock indicator will light. To unlock, repeat above procedure.

### DISPLAY SETTING

- To change readout from Celsius to Fahrenheit or vice versa: Press Temp Down pushbutton simultaneously with the Fan pushbutton.

### REMOTE CONTROL UNIT

Many models have a remote control unit which can adjust the thermostat remotely.

- The remote control has duplicated the thermostat input pushbuttons including: the ON/OFF pushbutton, TEMP UP/DOWN, FAN, MODE, SLEEP, and TIMER pushbuttons
- LEDs in the thermostat control respond to a pushbutton actuation from the remote control unit in the same manner as it would respond to the pushbutton actuation on the thermostat control.
- The remote control requires a CR2025 battery commonly available.



# OPERATING INSTRUCTIONS FOR ADJUSTING THE THERMOSTAT

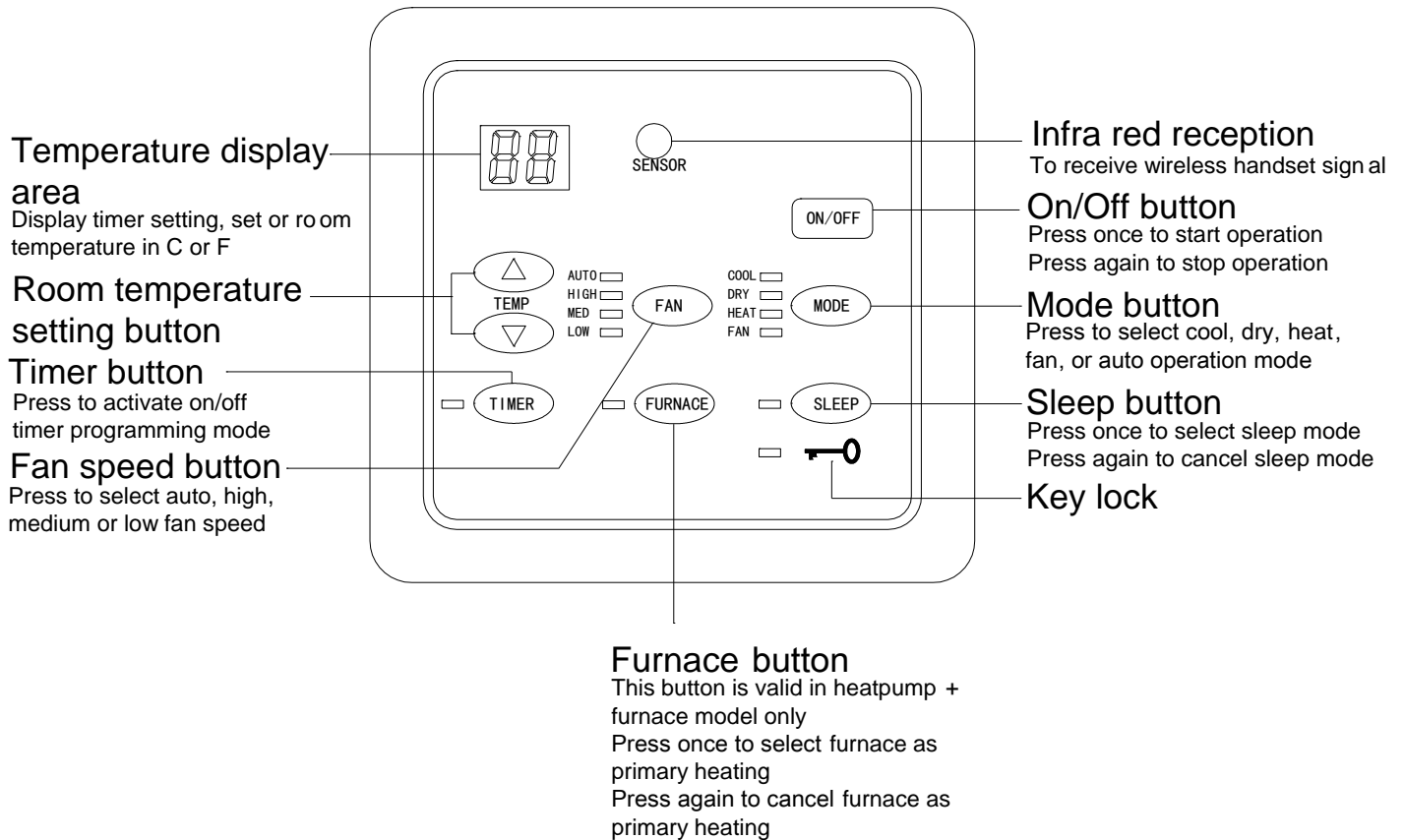

## 1. Power On/Off

- ◆ Press **ON/OFF** to start or stop the air conditioner.

## 2. Temperature setting

- ◆ Press **▽** or **△** to decrease or increase the set temperature. When any of these buttons is pressed, temperature display area will flash with the old temperature setting for 4 seconds. Should there be no further key press it will then return to room temperature display in the range of 0C-50C.
- ◆ Press **▽** and **FAN** together for 5 seconds will change the temperature setting from C to F. Valid temperature set range is 16C-30C or 60F-85F.
- ◆ Temperature setting is bypassed in Fan mode.
- ◆ Temperature display according to set temp. Press **SLEEP** button for 5sec to show room temp until key is released. In degree F setting, 100 is shown as A0, 110 as B0, 120 as C0, 130 as D0, 140 as E0 and 150 as F0.

## OPERATING INSTRUCTIONS FOR ADJUSTING THE THERMOSTAT (cont)

### 3. Mode setting

- ◆ Press **MODE** button to change the operation mode as follow:-

Cool→Dry→Heat→Fan→Auto Cool/Heat

Heat and Auto mode is not available for cooling only model. Auto mode is not available for model where furnace is primary heating.

- ◆ Heat LED flashes during outdoor defrost cycle. **MODE** button press is invalid during this cycle.

### 4. Overriding

- ◆ This function is available in heat pump + furnace model only.
- ◆ Press **FURNACE** button to activate furnace as primary heating. Heat pump operation will be inhibited thereafter. Press the same button again to disable overriding function.

### 5. Fan speed setting

- ◆ Press **FAN** button to change the fan speed : Auto→High→Medium→Low. Auto fan setting is bypass in Fan mode. Fan speed setting is bypass in dry mode.
- ◆ When furnace is working as primary heat source in heat mode, pressing **FAN** button for 5sec to turn the fan off, display will show “FF” until button is released. Pressing **FAN** button again for 5sec to let the fan continue running, display will show “F0” until button is released.

### 6. Sleep setting

- ◆ Press **SLEEP** button to activate or deactivate sleep setting. Sleep is bypass in Fan and Dry mode.

## OPERATING INSTRUCTIONS FOR ADJUSTING THE THERMOSTAT (cont)

### 7. On/Off timer setting

- ◆ When the system is on, setting the timer will turn off the unit after the programmed hours were counted down. When the system is off, setting the timer will turn on the unit after the programmed hours were counted down.
- ◆ Press **TIMER** button once to activate on/off timer programming mode. Timer LED and temperature display area flash for 3 seconds showing the number of count down hours left. Thereafter, Timer LED flashes and temperature display area shows the timer setting.
- ◆ Press **TIMER** again to set the timer from 1 to 24 hours in 1 hour incremented in a round robin pattern.
- ◆ Hold down this key will change the timer setting automatically every half second.
- ◆ Press **TIMER** until the display shows “—“ will cancel the timer setting.
- ◆ Should there be no further button press, system will exit from on timer programming mode automatically.
- ◆ Timer LED will light up if on/off timer is set.
- ◆ Press **ON/OFF** to start or stop the air conditioner will also cancel the timer setting.

### 8. Error code display

- ◆ Should there be any fault happen with the main board, the relevant error code will be shown on the temperature display area.
- ◆ If there is multiple faults happen at the same time, the error code will be shown one after another.
- ◆ System will alternate the display of error code and room temperature.
- ◆ Depends on the model of main board, the error codes available are:

Fault	Error code
Room sensor failure	E1
Indoor coil sensor failure	E2
Outdoor coil sensor failure	E3
Insufficient of refrigerant	E4
Compressor overload	E5
Not used	E6
Not used	E7
Outdoor air sensor failure	E8
Wall pad room sensor failure	E9

## TROUBLESHOOTING

Control Pad will not illuminate when ON/OFF button is pressed

- Check circuit breaker is on
- Control cable may be unplugged between outside unit and inside fascia
- Check power supply to vehicle

Unit does not cool

- Check circuit breaker is on
- Control cable may be unplugged between outside unit and inside fascia
- Check power supply to vehicle

Unit does not heat

- Ensure mode has been switched to heat (check green LED)
  - Thermostat set point must be above room temperature
- Note: The compressor has a 3 minute delay before starting
- In very cold conditions the unit will take more time to start producing warm air

Insufficient cooling capacity

- Ensure return air filters are clean
- Operate the unit on high fan speed to obtain maximum capacity
- Ensure all windows, doors, skylights and hatches are closed and curtains/awnings used to reduce heat load, check for adequate insulation in roof & walls



## **LIMITED TWO-YEAR WARRANTY**

LIMITED TWO-YEAR WARRANTY AVAILABLE AT [WWW.DOMETIC.COM/WARRANTY](http://WWW.DOMETIC.COM/WARRANTY).

IF YOU HAVE QUESTIONS, OR TO OBTAIN A COPY OF THE LIMITED WARRANTY FREE OF CHARGE,  
CONTACT:

DOMETIC CORPORATION  
CUSTOMER SUPPORT CENTER  
1120 NORTH MAIN STREET  
ELKHART, INDIANA, USA 46514  
1-800-544-4881 OPT 3

NON-DUCTED AIR CONDITIONERS  
AC-1351

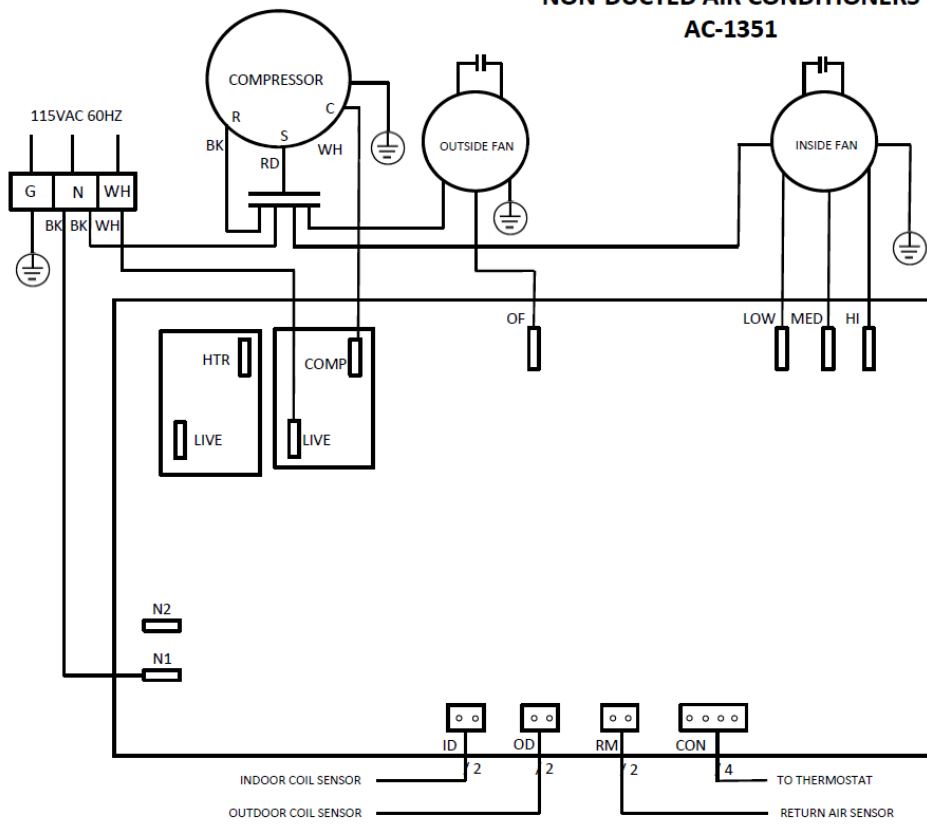

NON-DUCTED HEAT PUMPS  
AC-1501

