

# LoadLIFTER™ 5000

by AIR LIFT®

# Kit 57216 & 57128

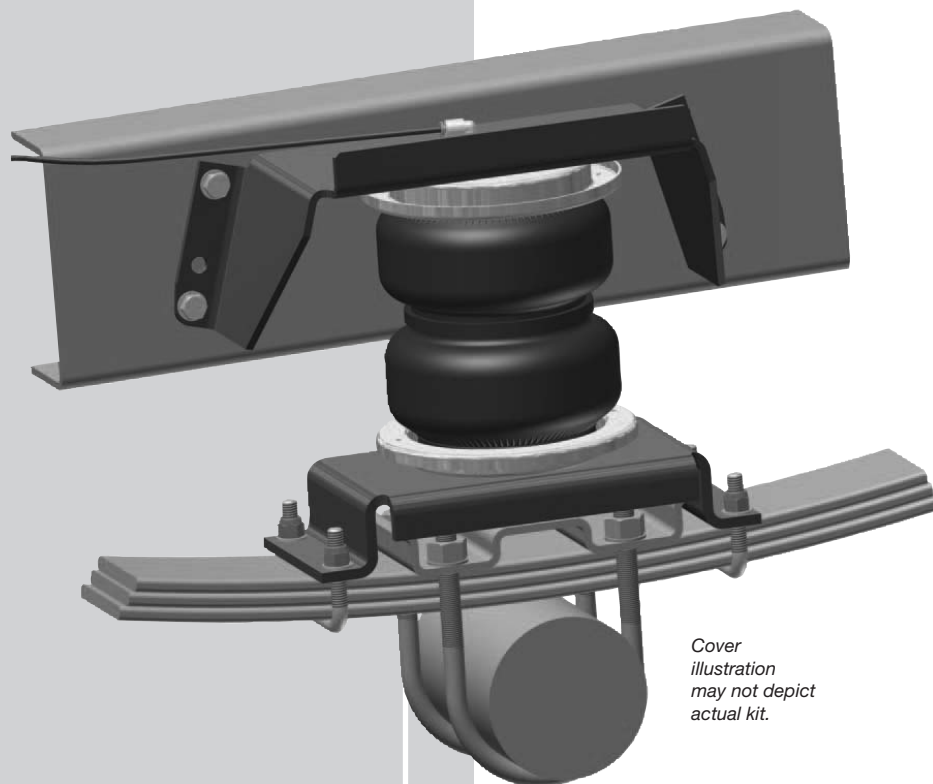

*Cover  
illustration  
may not depict  
actual kit.*



## INSTALLATION GUIDE

For maximum effectiveness and safety, please read these instructions completely before proceeding with installation.

*Failure to read these instructions can result in an incorrect installation.*





# TABLE OF CONTENTS

<b>Installation Diagram</b> .....	<b>2</b>
<b>Hardware and Tools Lists</b> .....	<b>3</b>
Hardware List .....	3
Tools List .....	3
<b>Introduction</b> .....	<b>4</b>
Notation Explanation .....	4
<b>Installing the LoadLifter 5000 System</b> .....	<b>5</b>
Getting Started .....	5
Raising the Vehicle .....	6
Removing the Jounce Bumper .....	6
Assembling the Air Spring Unit .....	6
Attaching the Lower Bracket .....	9
Attaching the Upper Bracket .....	9
Installing the Frame Brace .....	9
<b>Installing the Air Lines</b> .....	<b>11</b>
Installing the Heat Shield .....	11
Installation Checklist .....	12
<b>Maintenance and Use Guidelines</b> .....	<b>12</b>
Minimum Recommended and Maximum Air Pressure .....	12
<b>Limited Warranty and Return Policy</b> .....	<b>12</b>



# Installation Diagram

## KIT 57216

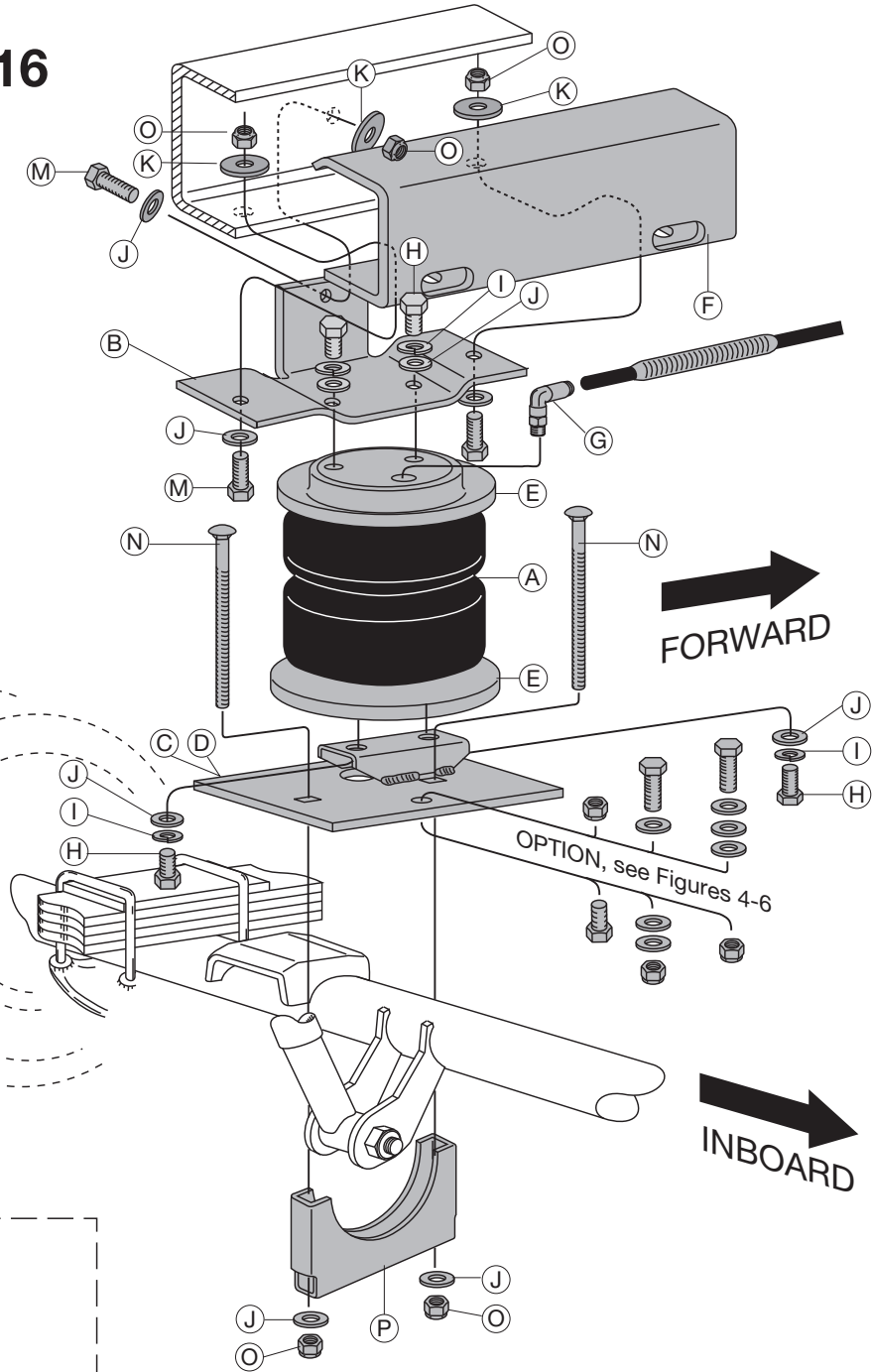

## KIT 57128

NOTE: No roll plates are used.

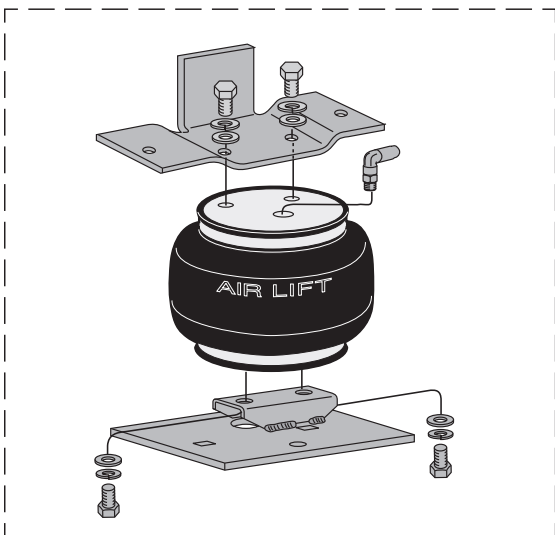

fig. 1

# Hardware and Tools Lists

## HARDWARE LIST

Item	Description .....	Qty	Item	Description .....	Qty
A	Air Spring.....	2	P	Axle Clamp.....	2
B	Upper Bracket.....	2	Q	Heat Shield*.....	1
C	Lower Bracket (Left).....	1	R	Clamp*.....	2
D	Lower Bracket (Right).....	1	S	Thermal Sleeve.....	1
E	Roll Plate (not in 57128).....	4	<b>Air Line Assembly Parts</b>		
F	Frame Brace.....	2	AA	Air Line Assembly.....	1
G	Elbow Fitting.....	2	BB	Zip Tie*.....	6
H	3/8"-24 x 7/8" Bolt.....	8	CC	Valve Caps*.....	2
I	3/8" Lock Washer.....	8	DD	5/16" Stainless Steel Flat Washer*.....	2
J	3/8" Flat Washer.....	24	EE	Rubber Washer*.....	2
K	3/8" Oversized Flat Washer.....	6	FF	Stainless Steel Star Washer*.....	2
L	3/8"-16 x 3/4" Bolt.....	2	GG	5/16" Hex Nut*.....	4
M	3/8"-16 x 1 1/2" Bolt.....	8	(* not shown in Figure 1)		
N	3/8"-16 x 6" Carriage Bolt.....	4			
O	3/8" Nylon Lock Nut.....	12			

## TOOL LIST

Description.....	Qty
STD and Metric Open-end or box wrenches.....	1
Adjustable Wrench.....	1
Ratchet with 3/8", 9/16", and 1/2" deep well sockets....	1
3/8" and 5/16" drill bits (very sharp).....	1
3/8" Nut Driver.....	1
Heavy Duty Drill.....	1
Torque Wrench.....	1
Hose Cutter, Razor Blade, or Sharp Knife.....	1
Hoist or Floor Jacks.....	1
Safety Stands.....	2
Safety Glasses.....	1
Air Compressor, or Compressed Air Source.....	1
Spray Bottle with Dish Soap/Water Solution.....	1



Missing or damaged parts? Call Air Lift customer service at (800) 248-0892 for a replacement part.

# Introduction

The purpose of this publication is to assist with the installation and maintenance of the LoadLifter 5000 air spring kits. All LoadLifter 5000 kits utilize sturdy, reinforced, commercial-grade single or double, depending on the kit, convolute bellows. They also incorporate an internal jounce bumper.

The air springs are manufactured like a tire with layers of rubber and cords that control growth. LoadLifter 5000 kits provide up to 5,000 pounds (2,268kg) of load-leveling support with air adjustability from 5-100 PSI (.34-7BAR).

It is important to read and understand the entire installation guide before beginning installation or performing any maintenance, service or repair.

## NOTATION EXPLANATION

Hazard notations appear in various locations in this publication. Information which is highlighted by one of these notations must be observed to help minimize risk of personal injury or possible improper installation which may render the vehicle unsafe. Notes are used to help emphasize areas of procedural importance and provide helpful suggestions. The following definitions explain the use of these notations as they appear throughout this guide.



**DANGER**

INDICATES IMMEDIATE HAZARDS WHICH WILL RESULT IN SEVERE PERSONAL INJURY OR DEATH.



**WARNING**

INDICATES HAZARDS OR UNSAFE PRACTICES WHICH COULD RESULT IN SEVERE PERSONAL INJURY OR DEATH.



**CAUTION**

INDICATES HAZARDS OR UNSAFE PRACTICES WHICH COULD RESULT IN DAMAGE TO THE MACHINE OR MINOR PERSONAL INJURY.

# Installing the LoadLifter 5000 System

## NOTE

This instruction manual is for kits 57216 and 57128. The only difference between the two kits is the air spring. The drawings depict a double convolute bellow, as found in kit 57216. But all instructions and illustrations apply to kit 57128 as well, which uses a single convolute bellow.

The air springs will last much longer if they are not the suspension limiter in either compression or extension. The air spring compresses to 2.8" (71mm) and extends to 9.1" (231mm). Regardless of load, the air pressure should always be adjusted so that the Normal Ride Height is maintained at all times. The shock absorber is usually the limiter on extension. If this is not the case, then the use of limiting straps should be considered, in particular for vehicles that are used off-road.

## CAUTION

COMPRESSED AIR CAN CAUSE INJURY AND DAMAGE TO THE VEHICLE AND PARTS IF IT IS NOT HANDLED PROPERLY. FOR YOUR SAFETY, DO NOT TRY TO INFLATE THE AIR SPRINGS UNTIL THEY HAVE BEEN PROPERLY SECURED TO THE VEHICLE.

## GETTING STARTED

1. The 57216 kit requires a minimum of 7 1/4" (184mm) from the top of the jounce bumper strike plate to the bottom of the frame rail. Before installation is begun, check for sufficient clearance. If the measurement is less than 7 1/4" (184mm), then use kit 57128 (Fig. 2).

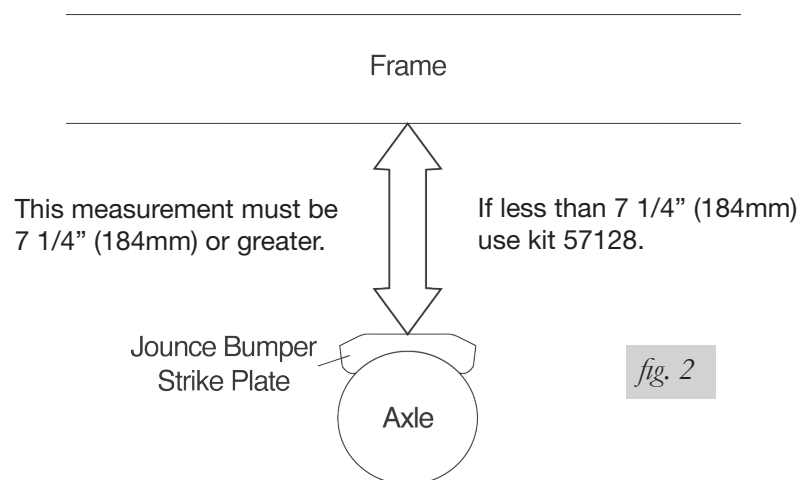

2. Determine the normal ride height. The normal ride height is the distance between the bottom edge of the wheel well and the center of the hub with the vehicle in the "as delivered" condition. In some cases, normal ride height is not perfectly level.
  - a. Remove unusual loads and examine your vehicle from the side to ensure it is on a level surface.
  - b. If necessary (in cases where your leaf springs are sagging badly), use a jack to raise the rear end so that the vehicle achieves the original "as delivered" ride height.

3. Measure the distance between the center of the hub and the bottom edge of the wheel well (Fig. 3). This is the normal ride height. Enter the measurement below:

NORMAL

RIDE HEIGHT: \_\_\_\_\_ inches/millimeters

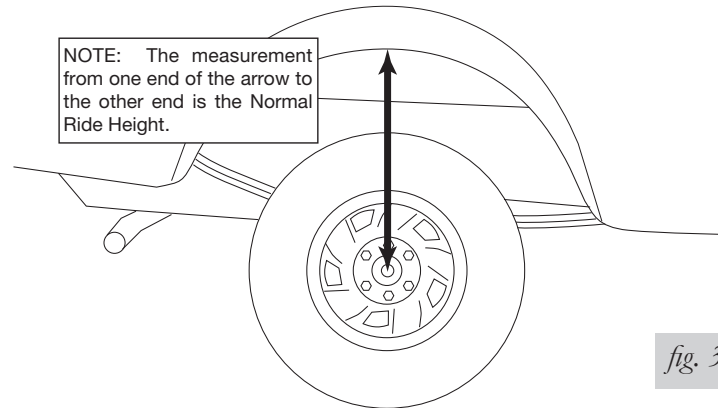

## RAISING THE VEHICLE

1. Raise the vehicle and remove the wheels.
2. Check the distance between the center of the hub and the bottom edge of the wheel to ensure that it is at the normal ride height previously recorded. If not, raise the frame or lower the axle as necessary to restore the original distance.
  - a. If the vehicle is raised with an axle contact hoist, then place axle stands under the frame and lower the axle as needed.
  - b. If the vehicle is raised with a frame contact hoist, then place axle stands under the axle and raise the frame as needed.
  - c. If the vehicle is raised with a jack and supported with axle stands on the frame, then use a floor jack to lower the axle.

## REMOVING THE JOUNCE BUMPER

1. Remove the jounce bumper by prying it off of the jounce bumper bracket.
2. Remove the jounce bumper bracket from the frame rail. It may be bolted or riveted. If riveted, it can be removed by center punching and drilling out the rivets, chiseling or grinding it off, or cutting it off with a torch.

## ASSEMBLING THE AIR SPRING UNIT

1. The lower brackets (C and D) are designated left (driver's side (indicated by the "L" stamped on it) and right (passenger's side (indicated by the stamped "R").
2. It will be necessary to use either the 3/8"-16 x 3/4" bolt (L) or the 3/8"-16 x 1 1/2" (M) in combination with flat washers (J) and a nylon lock nut (O) as a spacer stack so that the lower bracket sits flat on the axle housing/jounce bumper pad.
3. Set the lower bracket on the axle housing to determine the appropriate spacer stack up.



**NOTE**

As a general rule, 1/2 and 3/4 ton trucks and some 1 ton trucks with single rear wheels take the stack in Figure 4. Most 1 ton single rear wheels and some 1 ton dual rear wheel trucks take the stack in Figure 5. Most 1 ton dual rear wheel trucks take the stack in Figure 6.

For 1/2- and 3/4- ton trucks and some 1-ton trucks with single rear wheels.

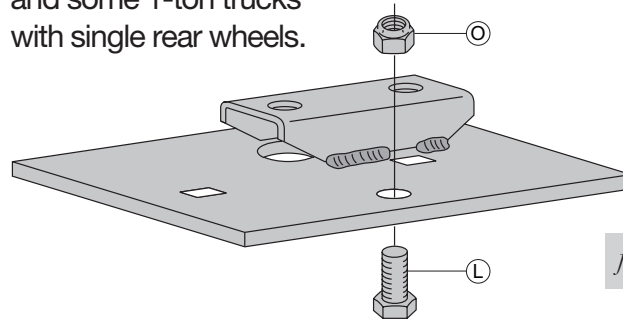

fig. 4

For most 1-ton trucks with single rear wheels and some 1-ton trucks with dual rear wheels.

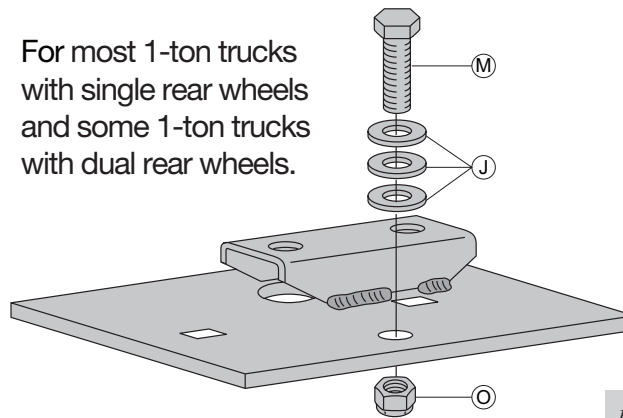

fig. 5

For most 1-ton trucks with dual rear wheels.

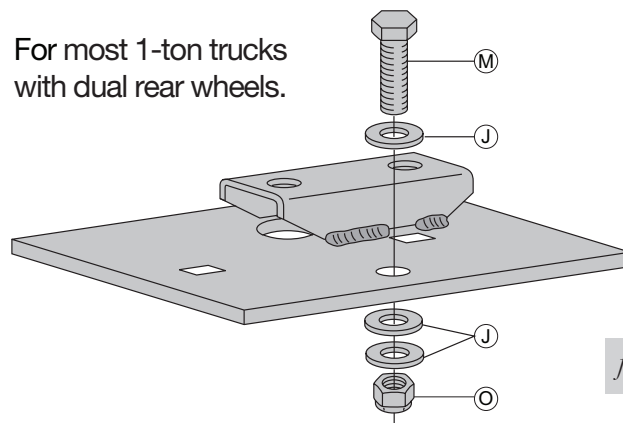

fig. 6

4. Due to manufacturing tolerances, the shock mounting bracket may stop the lower bracket from sitting completely flat on the axle housing/jounce bumper pad. This may occur on only one side of the vehicle. In such instances, it will be necessary to use a grinder to trim the shock bracket until it is flat with the top of the axle housing (Fig. 7).

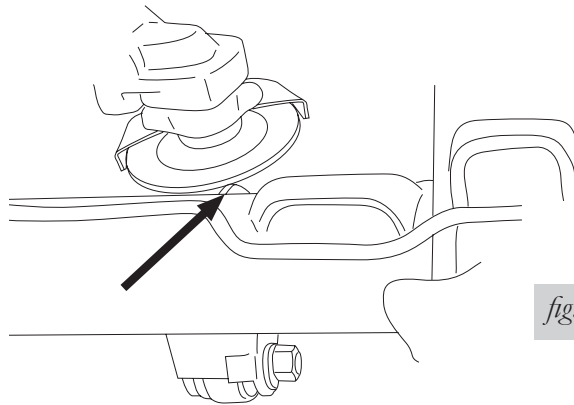

fig. 7

5. After determining and installing the appropriate stackup, insert one carriage bolt (N) into the forward hole of the lower bracket (Fig. 8).

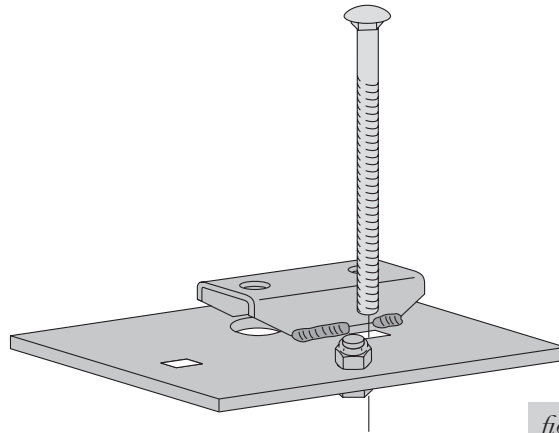

fig. 8

6. Set a roll plate (E) on both ends of the double convolute air spring (Fig. 1). **Kit 57128 with the single convolute air spring does not require roll plates.**
7. Set the air spring assembly onto the lower bracket. The spacer assembly on the lower bracket must be positioned on the same side as the air port on the top of the air spring.
8. Attach the lower bracket to the air spring using two bolts (H), two lock washers (I), and two flat washers (J) (Fig. 1).
9. Attach the upper bracket (B) to the air spring using two bolts (H), two lock washers (I), and two flat washers (J). Be sure that the tall vertical leg of the upper bracket is opposite of the air fitting port (Fig. 1).
10. Repeat assembly for other side.

## ATTACHING THE LOWER BRACKET

1. Set the assembly on the axle with the tall, wide vertical leg of the upper bracket on the outside of the frame rail. The lower bracket spacer sets just inboard of the jounce bumper pad on the axle housing.
2. Some models may require prying the brake line slightly away from the axle so that the axle clamp will not pinch the brake line.
3. Insert a carriage bolt (N) into the rearward hole in the lower bracket. Attach the bracket using the axle clamp (P), flat washers (J), and lock nuts (O). Torque to 20 lb.-ft. (27Nm).

## ATTACHING THE UPPER BRACKET

1. Align the air spring vertically and horizontally and clamp the upper bracket to the frame rail using locking pliers or c-clamp.



### CAUTION

BEFORE DRILLING, BE SURE TO CHECK THE BACK SIDE OF THE FRAME RAIL FOR BRAKE LINES, GAS LINES, OR ELECTRICAL LINES THAT MAY BE IN THE WAY. IT IS NECESSARY TO MOVE ANY INTERFERING LINES PRIOR TO DRILLING.

2. Use the upper bracket as a template to center punch and drill a 3/8" hole through the outboard side of the frame rail and upper bracket (Fig. 9).

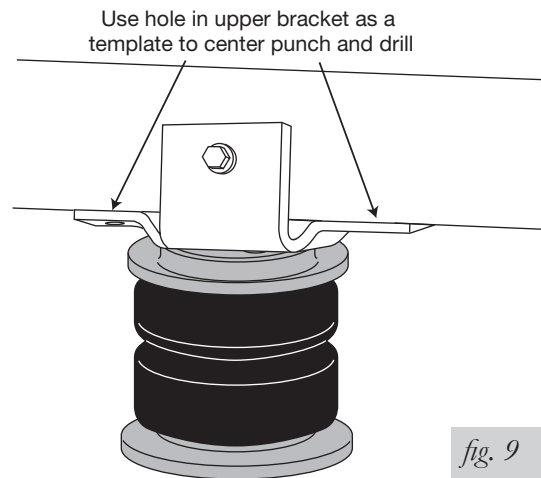

fig. 9

3. Install one bolt (M), one flat washer (J), one oversized flat washer (K), and a lock nut (O). Torque to 44 lb.-ft. (60Nm) and leave clamp in place.
4. Do not use the existing jounce bumper holes in the frame rail. Instead, use the holes in the upper bracket as a template along the bottom of the frame rail and center punch and drill two 3/8" holes through the holes in the upper bracket. Do not attach to the frame rail at this time. Remove the clamp or locking pliers.

## INSTALLING THE FRAME BRACE

1. It may be necessary to cut or trim off the plastic locator studs (on '97 and newer models) before installing the frame brace.
2. Install the frame brace (F) with the access holes toward the bottom of the frame rail. This is a tight fit and may require tapping with a hammer or mallet.
3. Align the access holes with the holes already drilled in the bottom of the frame. Using a large screw driver or punch through the already drilled hole, push the frame brace forward or backward until the holes are aligned.

4. Install a bolt (M), flat washer (J), oversized flat washer (K), and a lock nut (O). Hold the lock nut with a 9/16" open end wrench through the access hole and tighten the bolt to 44 lb.-ft. (60Nm). Repeat for other mounting hole (Fig. 10).

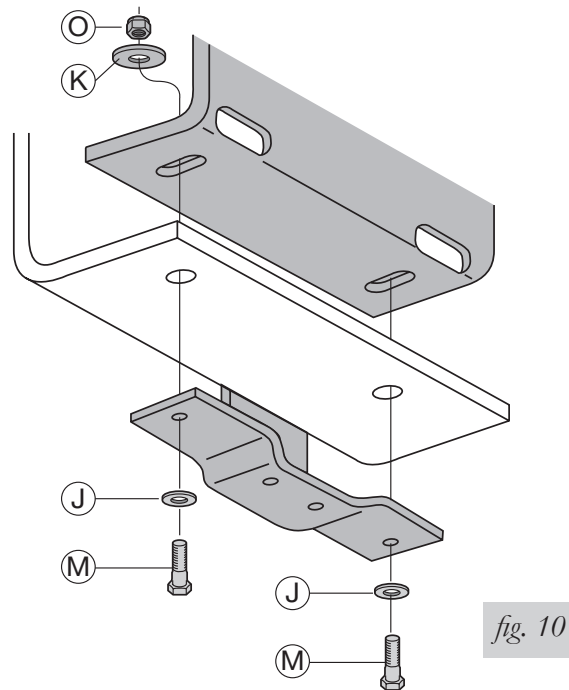

5. Install the air fitting into the air spring assembly. The threads are precoated with sealant. Tighten finger tight plus 1 1/2 turns, being careful to tighten only on the metal hex nut. Do not over tighten.

# Installing the Air Lines

Choose the locations for the Schrader valves and drill a 5/16" (8mm) hole, if necessary (Fig. 11).

1. Cut the air line in half. Make clean, square cuts with a razor blade or hose cutter (Fig. 12). Do not use scissors or wire cutters.

**CAUTION**

KEEP AT LEAST 6" (152MM) OF CLEARANCE BETWEEN ALL AIR LINES AND THE EXHAUST SYSTEM. AVOID SHARP BENDS AND EDGES.

2. Use zip ties to secure the air line to fixed points along the chassis. Do not pinch or kink the air line. Leave at least 2" (50mm) of slack in the air line to allow for any movement that might pull on the air line. The minimum bend radius for the air line is 1" (25mm).

3. Install the Schrader valve in the chosen location (Fig. 13).

- A. Inside fuel tank filler door
- B. Inside rear wheel wells
- C. License plate or rear bumper area

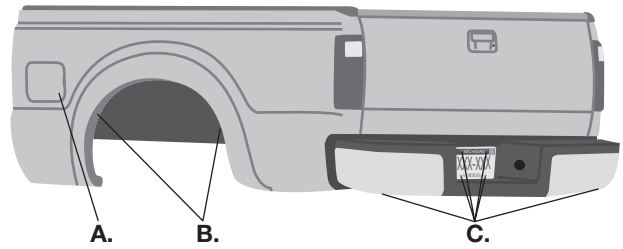

fig. 11

Good cut

Bad cut

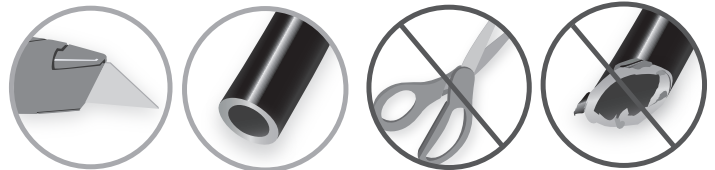

fig. 12

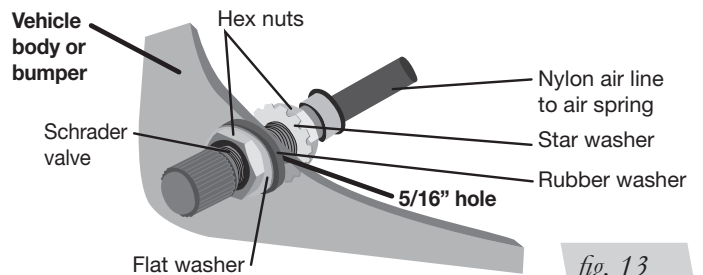

fig. 13

## INSTALLING THE HEAT SHIELD

1. Attach the metal heat shield to the exhaust where it is closest to the passenger's (right) side air spring. Slide the air line thermal sleeve over the air line and position it where the air line is closest to the exhaust. (Fig. 14).

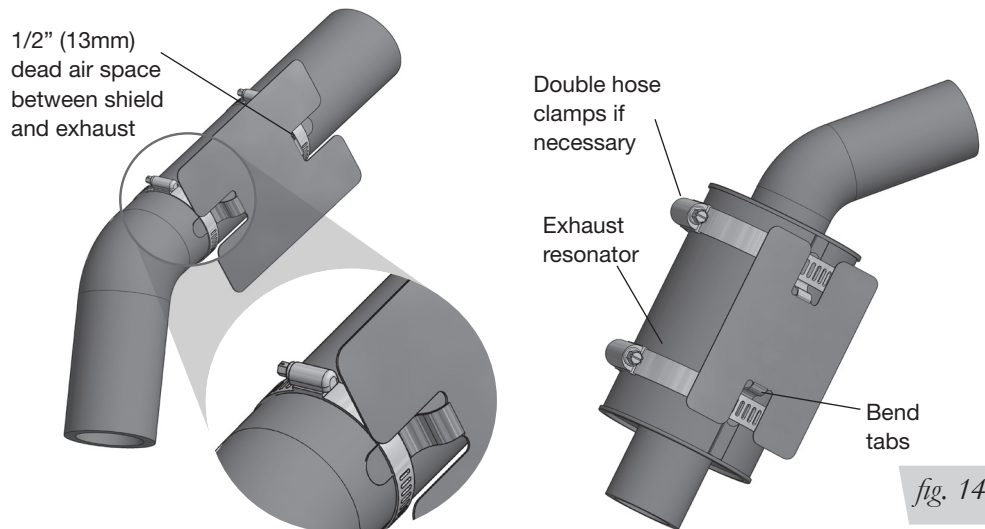

fig. 14

## INSTALLATION CHECKLIST

- Clearance test** — Inflate the air springs to 40-60 PSI (2.8-4.1BAR) and make sure there is at least 1/2" (13mm) clearance from anything that might rub against each sleeve. Be sure to check the tire, brakes, frame, shock absorbers and brake cables.
- Leak test before road test** — Inflate the air springs to 40-60 PSI (2.8-4.1BAR) and check all connections for leaks. All leaks must be eliminated before the vehicle is road tested.
- Heat test** — Be sure there is sufficient clearance from heat sources, at least 6" (152mm) for air springs and air lines. If a heat shield was included in the kit, install it. If there is no heat shield, but one is required, call Air Lift customer service at **(800) 248-0892**.
- Fastener test** — Recheck all bolts for proper torque.
- Road test** — The vehicle should be road tested after the preceding tests. Inflate the springs to recommended driving pressures. Drive the vehicle 10 miles (16km) and recheck for clearance, loose fasteners and air leaks.
- Operating instructions** — If professionally installed, the installer should review the operating instructions with the owner. Be sure to provide the owner with all of the paperwork that came with the kit.

## Maintenance and Use Guidelines

1. Check air pressure weekly.
2. Always maintain normal ride height. Never inflate beyond 100 PSI (7BAR).
3. If the system develops an air leak, use a soapy water solution to check all air line connections and the inflation valve core before deflating and removing the air spring.

Minimum Recommended Pressure	Maximum Air Pressure
<b>5 PSI (.34BAR)</b>	<b>100 PSI (7BAR)</b>

**CAUTION**

FOR SAFETY AND TO PREVENT POSSIBLE DAMAGE TO THE VEHICLE, DO NOT EXCEED MAXIMUM GROSS VEHICLE WEIGHT RATING (GVWR) OR PAYLOAD RATING, AS INDICATED BY THE VEHICLE MANUFACTURER.

**CAUTION**

ALTHOUGH THE AIR SPRINGS ARE RATED AT A MAXIMUM INFLATION PRESSURE OF 100 PSI (7BAR), THE AIR PRESSURE ACTUALLY NEEDED IS DEPENDENT ON LOAD AND GROSS VEHICLE WEIGHT RATING.

## Limited Warranty and Return Policy

Air Lift Company provides a limited lifetime warranty to the original purchaser of its load support products, that the products will be free from defects in workmanship and materials when used on cars and trucks as specified by Air Lift Company and under normal operating conditions, subject to the requirements and exclusions set forth in the full Limited Warranty and Return Policy that is available at [www.airliftcompany.com/warranty](http://www.airliftcompany.com/warranty).

For additional warranty information contact Air Lift Company customer service.



## Need Help?

Contact our customer service department by calling (800) 248-0892, Monday through Friday. For calls from outside the USA or Canada, our local number is (517) 322-2144.

**Register your warranty online at  
[www.airliftcompany.com/warranty](http://www.airliftcompany.com/warranty)**



*Thank you for purchasing Air Lift products — the professional installer's choice!*

Air Lift Company • 2727 Snow Road • Lansing, MI 48917 or PO Box 80167 • Lansing, MI 48908-0167  
Toll Free (800) 248-0892 • Local (517) 322-2144 • Fax (517) 322-0240 • [www.airliftcompany.com](http://www.airliftcompany.com)

Printed in the USA  
JJC-1118



California: ⚠️WARNING: Cancer and Reproductive Harm - [www.P65Warnings.ca.gov](http://www.P65Warnings.ca.gov)