

Load**LIFTER**7500**XL**TM



Installation Guide

Kit 57538

*Chevrolet/GMC
Heavy Duty*



Representative vehicle image

MN-1034 • (021810) • ECR 9155

For maximum effectiveness and safety, please read these instructions completely before proceeding with installation.

Failure to read these instructions can result in an incorrect installation.



Load**LIFTER**7500**XL**

Table of Contents

Installation Diagram	2
Hardware List and Tools List	3
Hardware List	3
Tools List	3
Introduction	4
Notation Explanation	4
Maintenance and Use Guidelines	4
Limited Warranty and Return Policy	4
Installing the LoadLifter 7500 XL System	5
Getting Started	5
Air Spring Assembly	6
Positioning the Air Spring Assembly on the Axle	7
Attaching the Upper Brackets	7
Reattaching the Emergency Brake Cable to the Frame	9
Attaching the Lower Brackets	10
Installing the Air Lines	11
Installing the Heat Shield	11
Finished Installation Photos.	12
Installation Checklist	13



Installation Diagram

NOTE: If the vehicle has fifth-wheel hitch brackets along the side of the frame, the U-bolts may not be used.

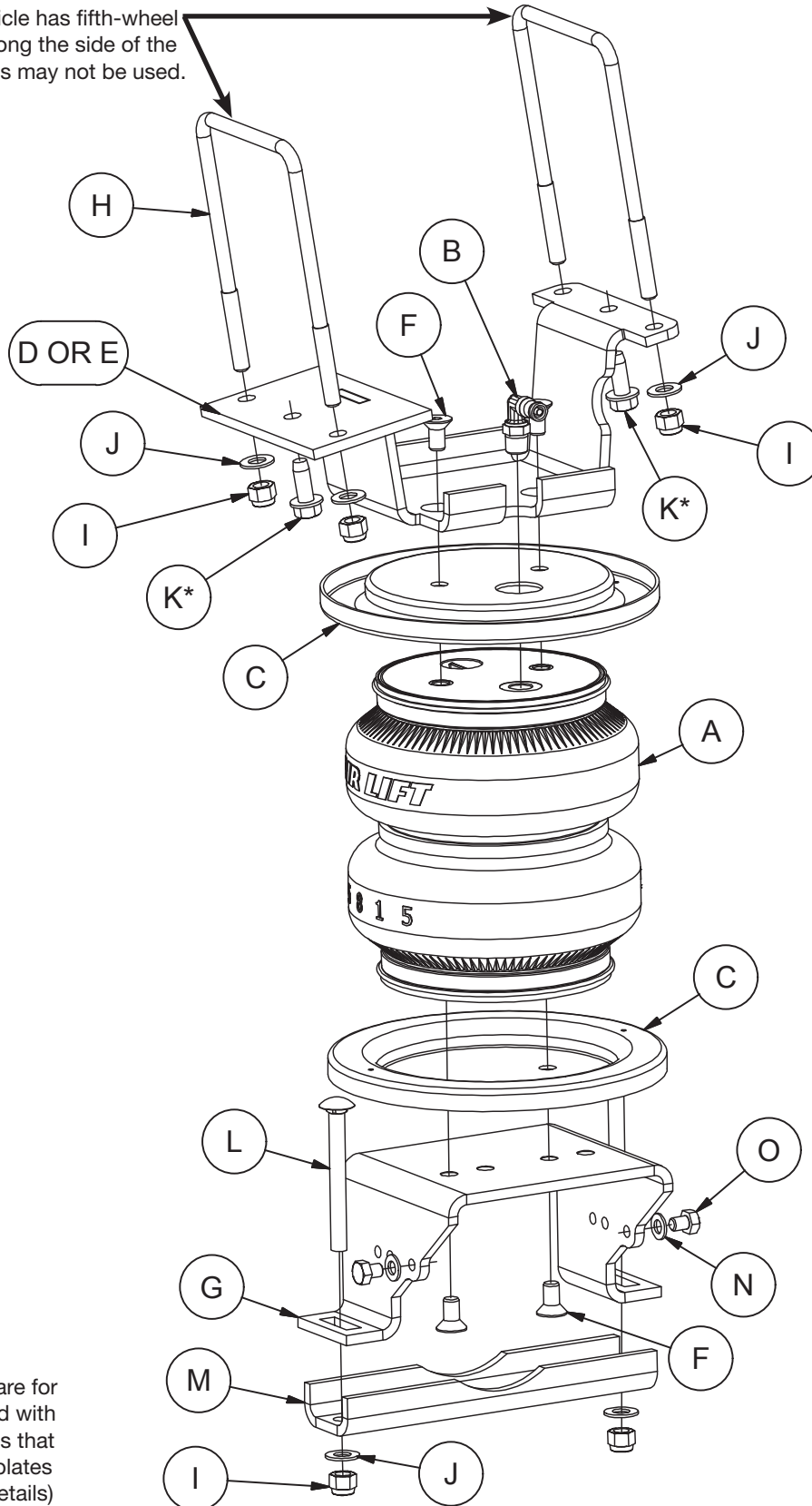

* Optional hardware for vehicles equipped with fifth-wheel hitches that have frame side plates (see page 9 for details)

fig. 1

Hardware and Tools Lists

HARDWARE LIST

Item	Part #	Description	Qty
A	58115	Air spring.....	2
B	21830	90-degree Swivel fitting	2
C	11897	Roll plate	4
D	07905	Upper bracket, right.....	1
E	07804	Upper bracket, left	1
F	17215	3/8"-24 x 3/4" Flat head screw	8
G	03702	Lower bracket	2
H	11046	U-bolt	4
I	18435	3/8"-16 Nylon lock nut	12
J	18444	3/8" Flat washer	12
K	17129	3/8" Self-tapping screws	4
L	17142	3/8"-16 x 3 1/2" Carriage bolts	4
M	01851	Clamp bar	2
N	18501	M8 Flat washer.....	5
O	17449	M8-1.25 x 10 Hex cap screw	3
P*	18422	3/8"-16 Serrated flange lock nut.....	1
Q*	26333	Emergency brake cable bracket	1
R*	10466	Zip ties	6
S*	21230	Valve cap.....	2
T*	21233	5/16" Hex nut.....	4
U*	21234	5/16" Rubber washer.....	2
V*	18411	Star washer	2
W*	20086	Air line assembly	1
X*	13955	Spacer.....	1

* not pictured in the Installation Diagram

TOOLS LIST

Description	Qty
Metric & STD open-end box wrenches	set
Ratchet with metric and STD sockets.....	set
Drill and 5/16" drill bit.....	1
Torque wrench.....	1
13mm Ratcheting wrench	1
Hex key wrenches metric and STD	set
Hose cutter, razor blade or sharp knife	1
Hoist or floor jack	1
Safety stands.....	2
Safety glasses	1
Air compressor or compressed air source	1
Spray bottle with dish soap/water solution.....	1



Missing or damaged parts? Call Air Lift customer service at (800) 248-0892 for a replacement part.

Introduction

The purpose of this publication is to assist with the installation of the LoadLifter 5000 series air spring kits. All LoadLifter 5000 series kits utilize sturdy, reinforced, commercial-grade single or double, depending on the kit, convolute bellows.

The air springs are manufactured like a tire with layers of rubber and cords that control growth. LoadLifter 5000 kits provide up to 5,000 pounds (2,268kg) of load-leveling support with air adjustability from 5-100 PSI (.34-7BAR).

It is important to read and understand the entire installation guide before beginning installation, as well as, read and understand the entire user guide before performing any maintenance, service or repair.

NOTATION EXPLANATION

Hazard notations appear in various locations in this publication. Information which is highlighted by one of these notations must be observed to help minimize risk of personal injury or possible improper installation which may render the vehicle unsafe. Notes are used to help emphasize areas of procedural importance and provide helpful suggestions. The following definitions explain the use of these notations as they appear throughout this guide.

DANGER

INDICATES IMMEDIATE HAZARDS WHICH WILL RESULT IN SEVERE PERSONAL INJURY OR DEATH.

WARNING

INDICATES HAZARDS OR UNSAFE PRACTICES WHICH COULD RESULT IN SEVERE PERSONAL INJURY OR DEATH.

CAUTION

INDICATES HAZARDS OR UNSAFE PRACTICES WHICH COULD RESULT IN DAMAGE TO THE MACHINE OR MINOR PERSONAL INJURY.

Maintenance and Use Guidelines

1. Check air pressure weekly.
2. Always maintain normal ride height. Never inflate beyond 100 PSI (7BAR).
3. If the system develops an air leak, use a soapy water solution to check all air line connections and the inflation valve core before deflating and removing the air spring.

Minimum Recommended Pressure	Maximum Air Pressure
5 PSI (.34BAR)	100 PSI (7BAR)

CAUTION

FOR SAFETY AND TO PREVENT POSSIBLE DAMAGE TO THE VEHICLE, DO NOT EXCEED MAXIMUM GROSS VEHICLE WEIGHT RATING (GVWR) OR PAYLOAD RATING, AS INDICATED BY THE VEHICLE MANUFACTURER.

CAUTION

ALTHOUGH THE AIR SPRINGS ARE RATED AT A MAXIMUM INFLATION PRESSURE OF 100 PSI (7BAR), THE AIR PRESSURE ACTUALLY NEEDED IS DEPENDENT ON LOAD AND GROSS VEHICLE WEIGHT RATING.

Limited Warranty and Return Policy

Air Lift Company provides a limited lifetime warranty to the original purchaser of its load support products, that the products will be free from defects in workmanship and materials when used on cars and trucks as specified by Air Lift Company and under normal operating conditions, subject to the requirements and exclusions set forth in the full Limited Warranty and Return Policy that is available at www.airliftcompany.com/warranty.

For additional warranty information contact Air Lift Company customer service.

Installing the LoadLifter 7500 XL System

GETTING STARTED

1. Raise and support the frame with safety stands. Lower the axle as far as possible (Fig. 2).

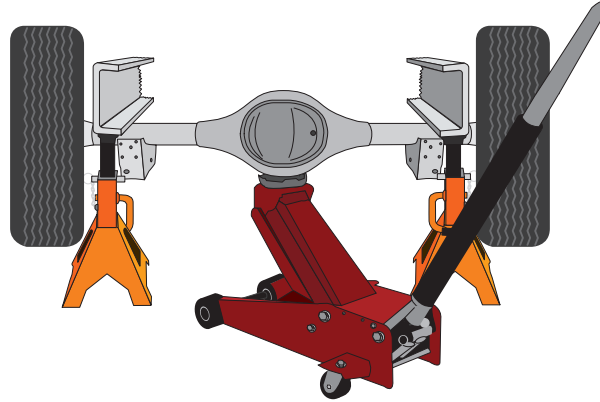
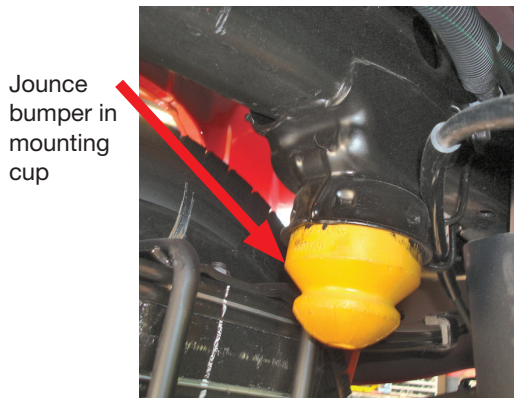

fig. 2

2. Remove the jounce bumper from the jounce bumper bracket on both sides of the vehicle by prying them out with a pry bar or large screwdriver (Figs. 3 & 4).



Jounce bumper in mounting cup

fig. 3

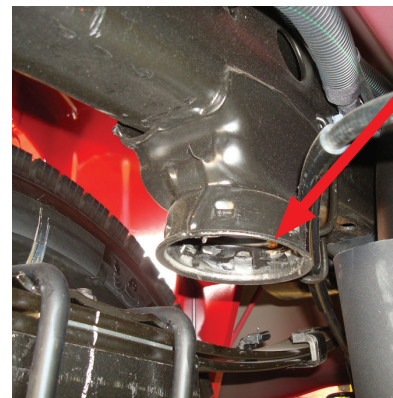

Jounce bumper removed

fig. 4

3. Remove the bolt that holds the emergency brake bracket to the inside of the driver's side frame rail (Figs. 5 & 6).

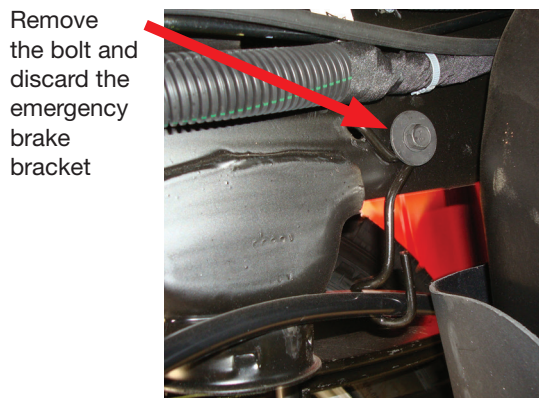

Remove the bolt and discard the emergency brake bracket

fig. 5



Bolt and emergency brake bracket removed

fig. 6

4. Remove the three bolts that hold the brake lines and emergency brake cable to the rear axle jounce bumper strike plates (Figs. 7 & 8).
5. Pull the emergency brake cables clear of the jounce bumper strike plate on the axle to make room for the lower bracket (Fig. 8).

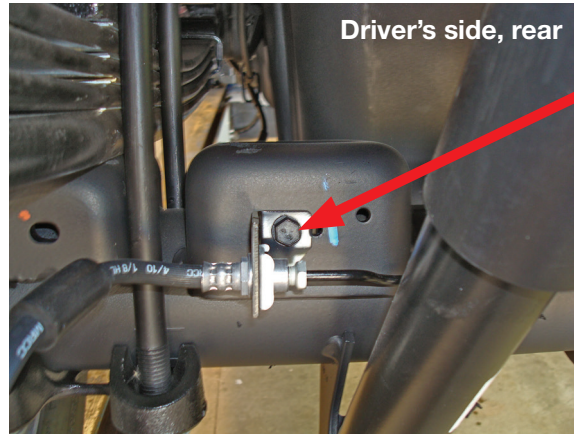

Remove the bolt holding the brake line to the jounce bumper strike plate in the rear on both driver's and passenger's side.

fig. 7

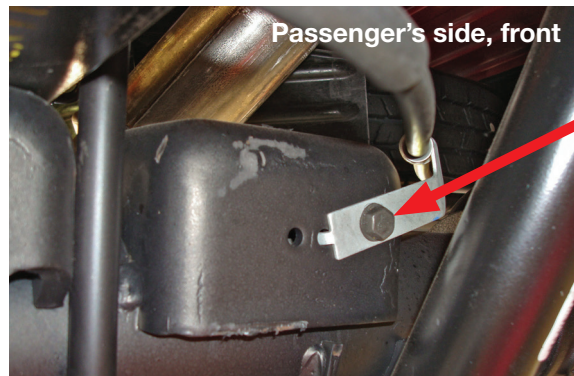

Remove the bolt holding the emergency brake cable on the front of the passenger's side jounce bumper strike plate.

fig. 8

AIR SPRING ASSEMBLY

1. Set a roll plate (C) on both ends of the air spring. The radiused (round) edge of the roll plate will be toward the air spring, enabling the air spring to be seated in both roll plates.
2. Install the 90-degree elbow fitting (B) on top of the air spring. Tighten finger tight plus 1 1/2 turns. Be careful to only tighten on the metal hex nut. Do not overtighten (Fig. 9).

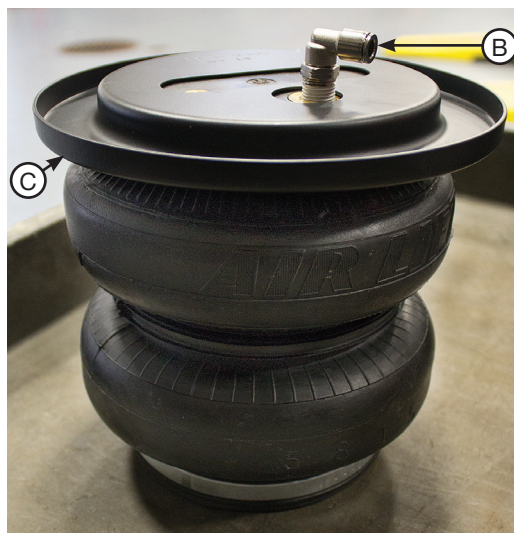
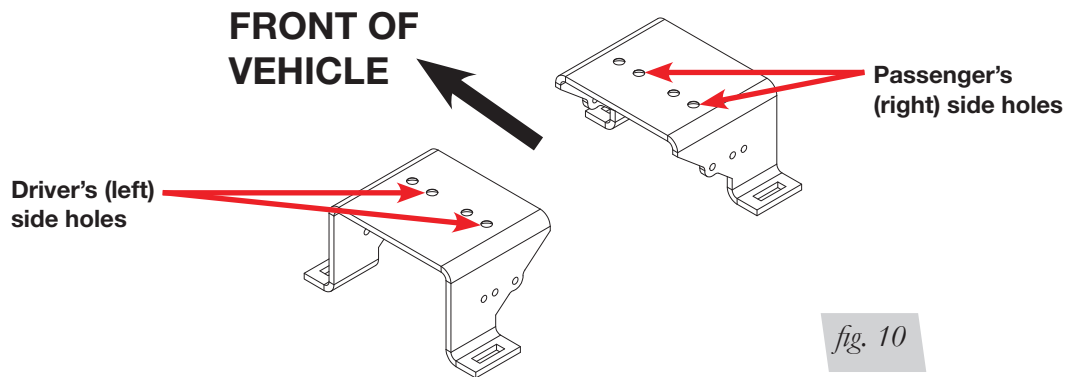

fig. 9

3. Install the upper brackets (D or E) onto the top of the air springs using the 3/8" flat-head bolts (F) (Fig. 10). Tighten securely.
4. To determine which holes in the lower bracket to use, set them next to each other with the angled sections pointing toward each other. Use the first and third holes on each bracket to attach the air springs. This will make them into left and right assemblies. Attach the lower bracket onto the air spring with two 3/8" flat-head screws (F) and torque to no more than 20 lb.-ft. (27Nm).

NOTE

The angled side of the lower bracket will be on the fitting side of the air spring (Figs. 1 & 10).

**POSITIONING THE AIR SPRING ASSEMBLY ON THE AXLE**

1. With the suspension hanging, set the left and right hand assemblies over the axle jounce bumper strike plates.

NOTE

The fittings will be on the inside of the frame.

2. Position the upper brackets to nest around the jounce bumper mount attached to the bottom of the frame.

ATTACHING THE UPPER BRACKETS

There are two ways of attaching the upper bracket:

For trucks that do not have a fifth-wheel hitch bracket alongside the frame:

NOTE

On late model vehicles, there is a heat shield above and forward of the axle, on the passenger's (right) side of the vehicle that will be in the way of the U-bolt. For models without a heat shield, proceed directly to step 3.

CAUTION

HEAT SHIELD HAS SHARP EDGES, USE CAUTION WHEN REMOVING THE BOLT.

1. On late model vehicles with a heat shield, use a ratcheting wrench to remove the bolt that holds the heat shield on the frame above and forward of the axle. Set the bolt aside (Fig. 11).

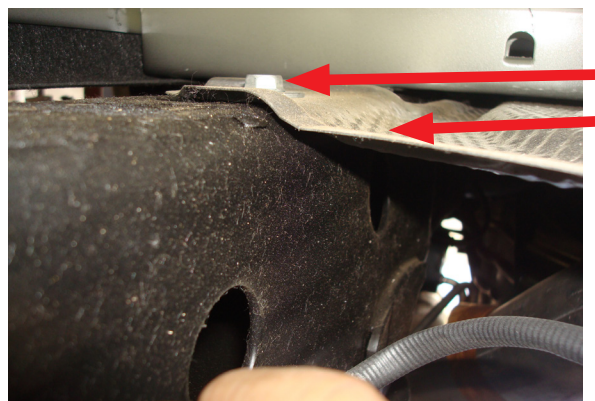

Bolt and heat shield located above and forward of the axle

fig. 11

2. Set spacer (X) between the frame and heat shield and reattach the heat shield with the stock bolt previously removed (Fig. 12).

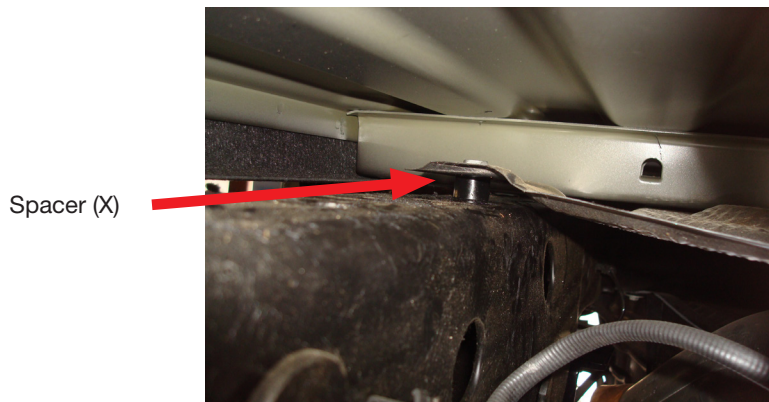

fig. 12

3. Insert two U-bolts (H) onto the top of the frame and through the upper bracket mounting holes (Fig. 13). The U-bolts must be between the frame and the brake lines and wiring.

NOTE

It may be necessary to raise the axle at this point for the upper bracket to reach the frame.

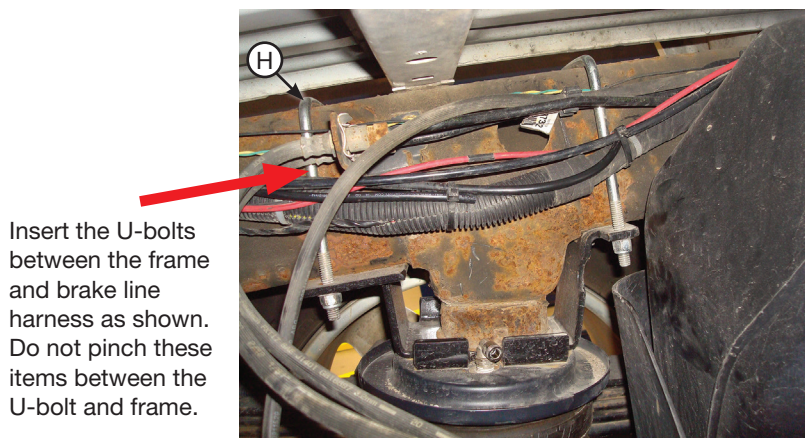

fig. 13

4. Cap with four 3/8" nylon lock nuts (I) and flat washers (J). Torque the U-bolts evenly in a criss-cross pattern to 10 lb.-ft. (14Nm). Repeat for the opposite side.

TECH TIP

Stuff a shop towel between the gas tank and shield to keep the washer and nut from falling in between in case they are dropped during installation.

CAUTION

THE DRIVER'S SIDE HAS A BRAKE LINE AND A WIRING HARNESS RUNNING ALONG THE INSIDE OF THE FRAME. MAKE SURE THE U-BOLT IS BETWEEN THESE ITEMS AND THE FRAME (DO NOT PINCH THESE ITEMS) (FIG. 13).

NOTE

On the passenger's side of some models, it might be necessary to bend the heat shield slightly to gain access for the U-bolt to go over the frame correctly (Fig. 14).

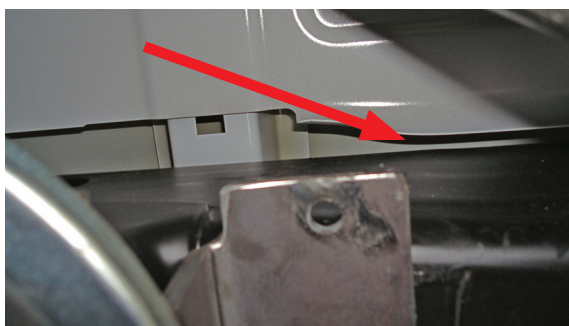

fig. 14

- Figure 15 shows the U-bolt installed on models that have the heat shield above and forward of the axle with spacer installed on passenger's (right) side. Continue with "Reattaching the Emergency Brake Cable to the Frame" section.



fig. 15

For trucks that have fifth-wheel hitch brackets alongside the frame rail:

- There are holes in the middle of the bracket just forward and behind the jounce bumper mounting cups on the upper bracket. Once the upper brackets are in position, drill two 5/16" holes through the bottom of the frame using the holes as a template and attach the upper brackets using the self tapping screws (K). Torque all four fasteners to 15 lb.-ft. (20Nm).

REATTACHING THE EMERGENCY BRAKE CABLE TO THE FRAME

- Attach the emergency brake cable removed in the "Getting Started" section with the emergency brake cable bracket (Q) and 3/8" serrated flange lock nut (P) (Fig. 16). Use the inside forward leg of the U-bolt on the driver's (left) side for the attachment. Tighten securely.

NOTE

It may be necessary to pinch the clamp together with pliers to align the two holes up enough to get over the U-bolts.

Emergency
brake cable

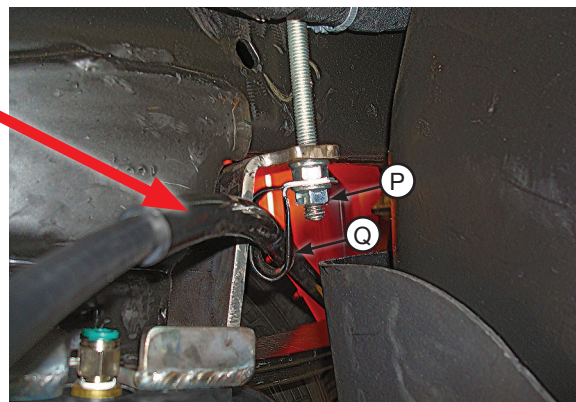

fig. 16

ATTACHING THE LOWER BRACKETS

1. Position the lower bracket to best align the air spring. Insert two 3/8" x 3 1/2" carriage bolts (L) through the lower bracket mounting legs (Fig. 17).

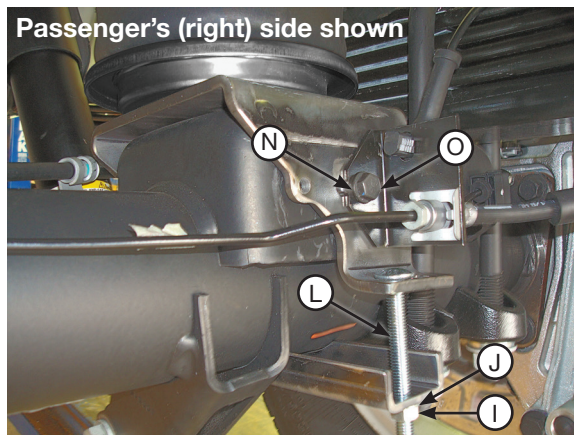

fig. 17

2. Insert the lower clamp bar (M) over the two carriage bolts previously installed and cap with two 3/8" nylon lock nuts (I) and flat washers (J). Torque evenly to 16 lb.-ft. (22Nm) (Fig. 17).
3. Attach the brake lines and emergency brake cable that were un-bolted from the rear of the axle in the "Getting Started" section by attaching them to the lower bracket with the new M8 screws (O) and flat washers (N) provided (Fig. 17). Tighten securely.
4. Attach the brake cable on the passenger's side, forward of the axle with the new M8-1.25 x 10 hex cap screw (O) and 3/8" flat washer (J) (Fig. 18). Tighten securely.

NOTE

It may be necessary to slightly bend this bracket to clear the edge of the lower bracket (Fig. 18).

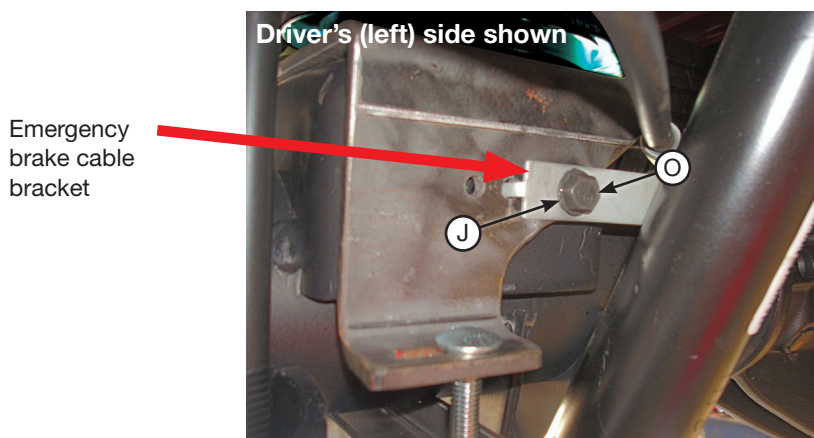

fig. 18

Installing the Air Lines

Choose the locations for the Schrader valves and drill a 5/16" (8mm) hole, if necessary (Fig. 19).

1. Cut the air line in half. Make clean, square cuts with a razor blade or hose cutter (Fig. 20). Do not use scissors or wire cutters.

CAUTION

KEEP AT LEAST 6" (152MM) OF CLEARANCE BETWEEN ALL AIR LINES AND THE EXHAUST SYSTEM. AVOID SHARP BENDS AND EDGES.

2. Use zip ties to secure the air line to fixed points along the chassis. Do not pinch or kink the air line. Leave at least 2" (51mm) of slack in the air line to allow for any movement that might pull on the air line. The minimum bend radius for the air line is 1" (25mm).
3. Install the Schrader valve in the chosen location (Fig. 21).

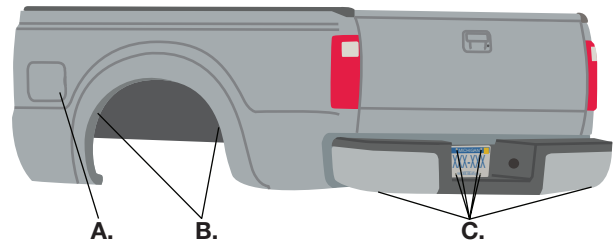

A. Inside fuel tank filler door
B. Inside rear wheel wells
C. License plate or rear bumper area

fig. 19

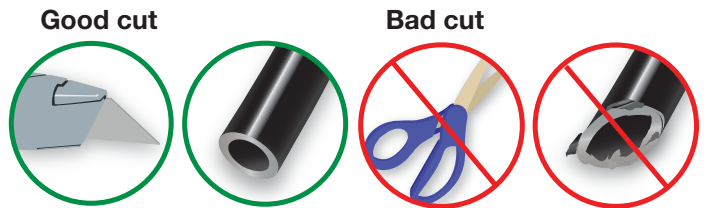

fig. 20

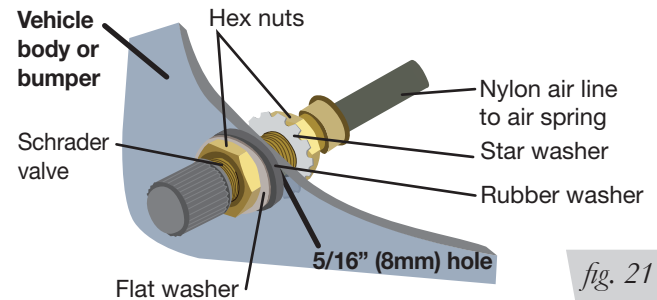

fig. 21

INSTALLING THE HEAT SHIELD

1. Attach the metal heat shield to the exhaust where it is closest to the passenger's (right) side air spring. Slide the air line thermal sleeve over the air line and position it where the air line is closest to the exhaust. (Fig. 22).

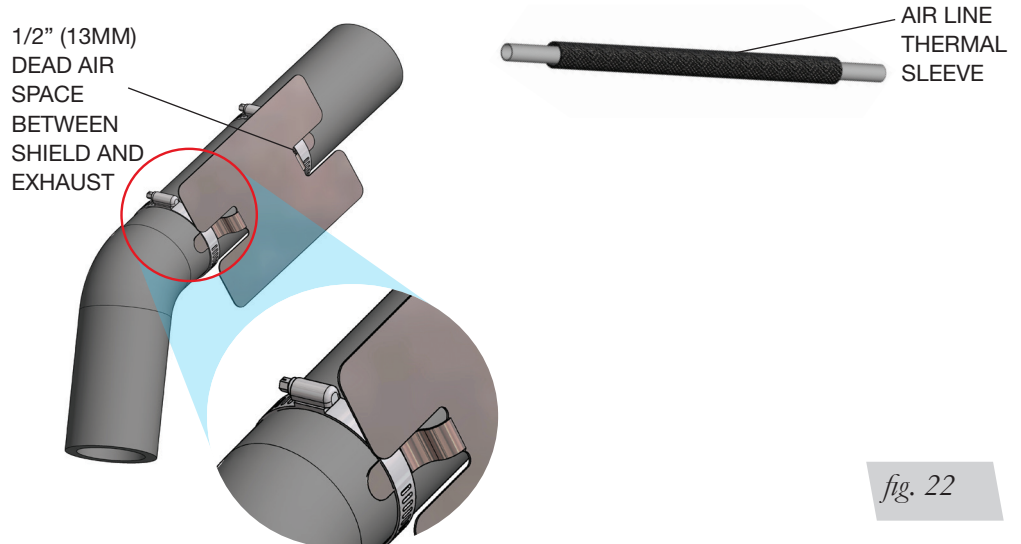

fig. 22

Finished Installation Photos

1. The following images show the finished installation of both sides (Figs. 23, 24, 25 & 26).



Driver's (left) side as viewed from the rear.



Passenger's (right) side as viewed from the middle of the vehicle.



Driver's (left) side as viewed from the middle rear of the vehicle.



Passenger's (right) side as viewed from the rear.

INSTALLATION CHECKLIST

- Clearance test** — Inflate the air springs to 40-60 PSI (2.8-4.1BAR) and make sure there is at least 1/2" (13mm) clearance from anything that might rub against each sleeve. Be sure to check the tire, brakes, frame, shock absorbers and brake cables.
- Leak test before road test** — Inflate the air springs to 40-60 PSI (2.8-4.1BAR) and check all connections for leaks. All leaks must be eliminated before the vehicle is road tested.
- Heat test** — Be sure there is sufficient clearance from heat sources, at least 6" (152mm) for air springs and air lines. If a heat shield was included in the kit, install it. If there is no heat shield, but one is required, call Air Lift customer service at **(800) 248-0892**.
- Fastener test** — Recheck all bolts for proper torque.
- Road test** — The vehicle should be road tested after the preceding tests. Inflate the springs to recommended driving pressures. Drive the vehicle 10 miles (16km) and recheck for clearance, loose fasteners and air leaks.
- Operating instructions** — If professionally installed, the installer should review the operating instructions with the owner. Be sure to provide the owner with all of the paperwork that came with the kit.

Need Help?

Contact Air Lift Company customer service department by calling (800) 248-0892.

For calls from outside the USA or Canada, dial (517) 322-2144.



Thank you for purchasing Air Lift products — the professional installer's choice!

Air Lift Company • 2727 Snow Road • Lansing, MI 48917 or P.O. Box 80167 • Lansing, MI 48908-0167
Toll Free (800) 248-0892 • Local (517) 322-2144 • Fax (517) 322-0240 • www.airliftcompany.com

Printed in the USA
JJC-1018

California: ⚠️WARNING: Cancer and Reproductive Harm - www.P65Warnings.ca.gov

