**WARNING:**

Do not inflate this assembly when it is unrestricted. The assembly must be restricted by the suspension or other adequate structure. Do not inflate beyond 100 P.S.I. Improper use or over inflation may cause property damage or severe personal injury.

INSTALLATION INSTRUCTIONS

Congratulations - your new air helper springs are quality products capable of improving the handling and comfort of your vehicle. As with all products, proper installation is the key to obtaining all of the benefits your kit is capable of delivering. Please take a few minutes to read through the instructions to identify the components and learn where and how they are used. It is a good idea to start by comparing the parts in your kit with the parts list below.

The heart of the air helper spring kit is, of course, the air springs. Remember that the air helper springs must flex and expand during operation, so be sure that there is enough clearance to do so without rubbing against any other part of the vehicle.

Be sure to take all applicable safety precautions during the installation of the kit. The instructions listed in this brochure and the illustrations all show the left or driver's side of the vehicle. To install the right side assembly simply follow the same procedures while reversing any orientations.

Your kit includes separate inflation valves and air lines for each air helper spring. This will allow you to level your vehicle from side to side as well as from front to back. If you would rather have a single valve inflation system, your dealer can supply the required T-fittings.

IMPORTANT!

For your safety and to prevent possible damage to your vehicle, do not exceed the maximum load recommended by the vehicle manufacturer (GVWR). Although your Air Helper Springs are rated at a maximum inflation pressure of 100 psi, this pressure may allow you to carry too great a load on some vehicles. It is best to have your vehicle weighed once it is completely loaded and compare that weight to the maximum allowed. Check your vehicle owner's manual or data plate on driver side door for maximum loads listed for your vehicle.

When inflating your Air Helper Springs, add air pressure in small quantities, checking pressure frequently during inflation. The air spring requires much less air volume than a tire and, therefore, inflates much quicker.

PARS LIST

AIR SPRING	6781	2	1/4" -20 HEX NUT	2
UPPER BRACKET RIGHT	5198	1	3/8" -16 x 1" HEX BOLT	8
UPPER BRACKET LEFT	5199	1	3/8" -16 x 3/4" FLANGED HEX BOLT	2
LOWER BRACKET RIGHT	5273	1	3/8" -16 FLANGED HEX NUT	20
LOWER BRACKET LEFT	5274	1	3/8" -16 x 3" CARRIAGE BOLT	4
LOWER BRACE RIGHT (L)	5271	1	18 FT. AIR LINE	0938 1
LOWER BRACE LEFT (L)	5272	1	PUSH-TO-CONNECT	
REAR BRACKET STRAP	1163	2	MALE FITTING	3046 2
BAIL CLAMP	3077	2	INFLATION VALVE	3032 2
HEATSHIELD	1004	1	5/16" FLAT WASHER	4
P-CLAMP	9179	1	THERMAL SLEEVE	0899 2
1/4" -20 x 1" HEX BOLT		2	NYLON TIE	8

FIGURE "A"

NOTE: This diagram is of the left or driver's side of the truck. Reverse any orientations when assembling and installing the right, or passenger's side of the vehicle.

**K
I
T

A
S
S
E
M
B
L
Y**

KIT TO FRAME ASSEMBLY

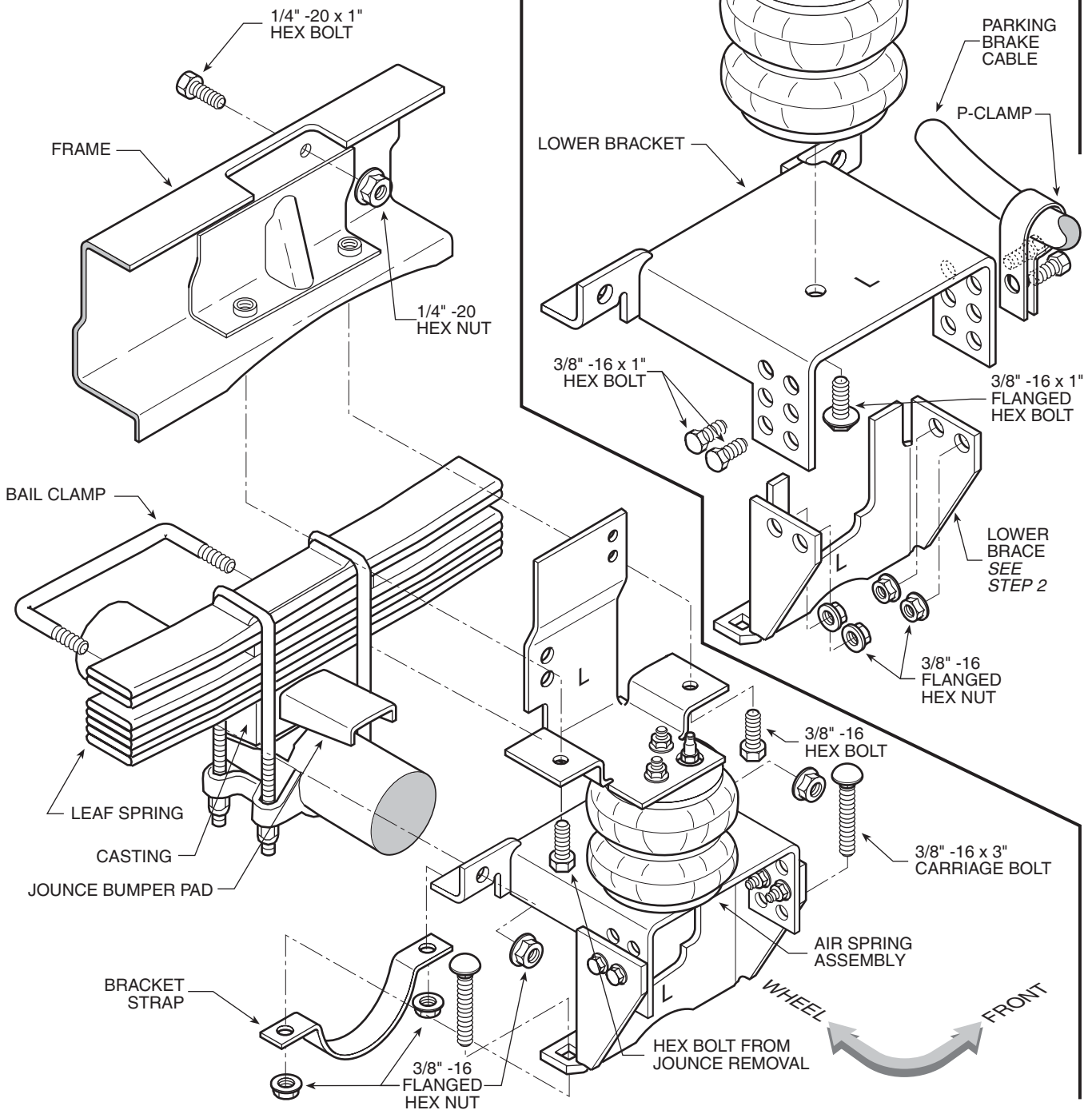

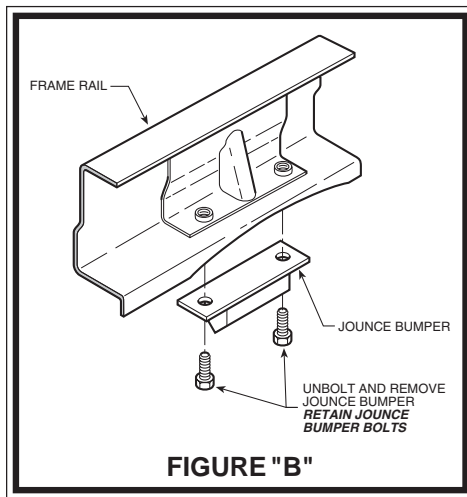

STEP 1 - PREPARE THE VEHICLE

With the vehicle on a solid level surface, chock the front wheels. This vehicle does not have to be jacked up to install this kit. Remove the negative battery cable. Remove the jounce bumpers by unbolting them from the frame *see Figure "B"*. The jounce bumpers will not be reused in this installation. Save the hex bolts used to secure the jounce bumper. They will be used later in this installation.

STEP 2 - ADJUST THE LOWER BRACE

Select the lower bracket and lower brace stamped "L" from your kit. Due to the variations in the jounce bumper pads, there are three different variations in which the lower bracket and lower brace can be bolted together *see Figure "C"*. The lower brace should rest against the axle housing. To determine which position to use, hold the lower bracket and the lower brace in place together. The lower bracket should be as level as possible. Insert the 3/8" -16 x 1" bolts through the holes in the lower bracket that align with the holes in the lower brace.

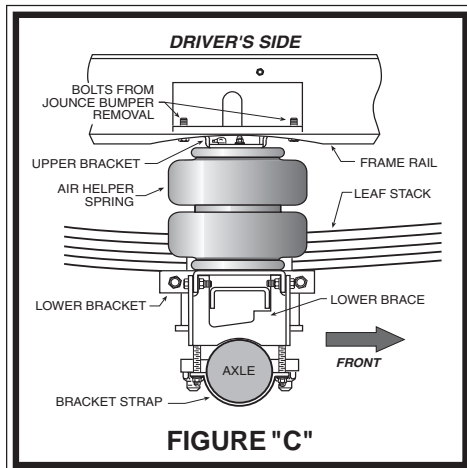

STEP 3 - PREASSEMBLE THE KIT

Note: The left and right brackets are stamped with the letters "L" or "R". ("L" for left and "R" for right)

Select the left side upper bracket and one air spring from your kit. Install the brass air fitting into the threaded hole (*finger tight*). Next, attach the upper bracket to the air spring using the 3/8" -16 flange lock hex nuts. Tighten the air fitting to engage at least two threads with the pre-applied orange thread sealant. Select the lower left bracket and lower left brace (*assembled in Step 2*) *see Figures "A" & "C"*. Fasten the lower left brace to the lower left bracket using the 3/8" -16 x 1" hex bolts (*inserted in Step 2*) and flanged hex nuts *see Figures "A" & "C"*. Attach the lower bracket assembly to the air spring using the 3/8" -16 x 3/4" flanged hex bolt (*finger tight*).

STEP 4 - INSTALL THE ASSEMBLY TO THE VEHICLE

Place the assembly on the vehicle by installing the upper bracket so that it lays against the outside of the frame rail *see Figure "D"*. The lower bracket will set over the top of the jounce bumper pad with the lower brace under the jounce bumper pad *see Figure "A"*. The lower bracket brace will set on top of the axle housing. Push the lower bracket toward the leaf spring until it rests against the leaf spring U-bolts.

Match the upper bracket to the existing holes in the frame rail left by the removal of the jounce bumper. Using the hex bolts from the jounce bumper removal, fasten the upper bracket to the bottom of the frame rail. The tab on the upper bracket will align with an existing hole on the outside of the frame rail. Using a 1/4" -20 flanged hex nut and 1/4" -20 x 1" hex bolt, fasten the upper bracket to the outside of the frame rail *see Figure "A"*.

Tighten the 3/4" -16 x 3/4" flanged hex bolt to secure the lower bracket to the air helper spring. Next, install the bail clamp around the casting. Insert the bail clamp through the holes in the lower bracket *see Figure "A"*. Install 3/8" -16 flanged hex nuts and draw the lower bracket against the leaf spring U-bolts. Next, attach the bracket straps to the lower left brace. Using two 3/8" -16 x 3" carriage bolts, attach the bracket straps to the lower left bracket brace, making sure that the bracket straps are holding the assembly securely on the axle housing *see Figure "A"*.

To provide adequate clearance, the parking brake cable must be repositioned so that it does not contact the air spring. Remove the factory clip between the parking brake cable and wire harness and attach the supplied P-clip to the lower bracket *see Figure "E"*. The remaining wire harness can be tied to the parking brake cable with the provided nylon ties *see Figure "E"*.

Make sure that the parking brake cable and wire harness will not contact the air spring or other undercarriage components.

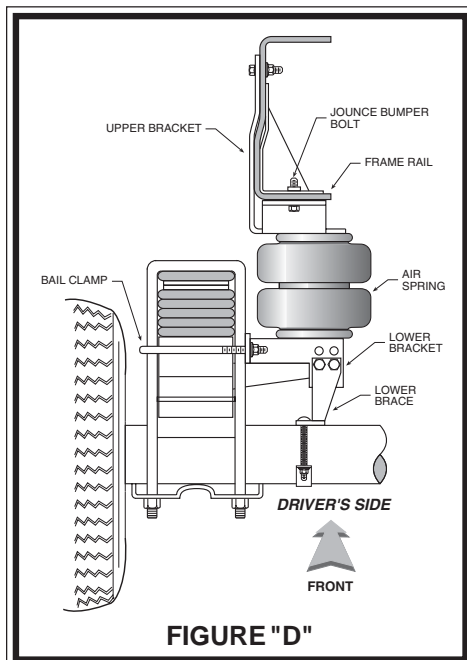

STEP 5 - INSTALL THE PASSENGER'S SIDE ASSEMBLY

To install the passenger's side, or right side assembly, follow Steps 2-4 while reversing any orientations. Use the brackets and brace stamped "R".

Note: The use of a heat shield is required on the passenger's side of the vehicle refer to Figure "F". The heat shield will mount between the upper bracket and the air spring. Adjust the heat shield so it will fall halfway between the air spring and the closest point on the exhaust. Be sure that the heat shield will not contact any vehicle component under full suspension compression (*brake lines, shock absorbers, lower bracket and brace assembly*).

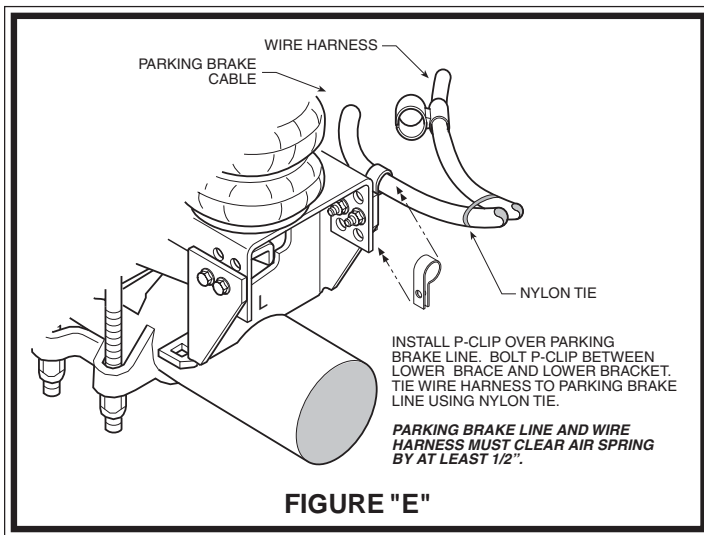

FIGURE "E"

STEP 6 - INSTALL THE AIR LINE

Uncoil the air tubing and cut it into two equal lengths. *DO NOT FOLD OR KINK THE TUBING.* Try to make the cut as square as possible. Insert one end of the tubing into the elbow fitting installed in the top of the air helper spring. Push the tubing into the fitting as far as possible refer to *Figure "A"*. Select a location on the bumper or the body of the vehicle, as long as it is in a protected location so the valve will not be damaged, but maintain accessibility for the air chuck see *Figure "G"*. Drill a 5/16" hole and install the air inflation valve using two 5/16" flat washers per valve as supports see *Figure "H"*. Run the tubing from the air spring to the inflation valve, avoiding direct heat from the engine, exhaust, and away from sharp edges. Thermal sleeves have been provided for these conditions. If a thermal sleeve is required, slide a thermal sleeve over the tubing to the location requiring protection. The air line tubing should not be bent or curved sharply, as it may buckle. Secure the tubing to the vehicle with the provided nylon ties. Push the end of the air line tubing into the inflation valve as illustrated see *Figure "H"*.

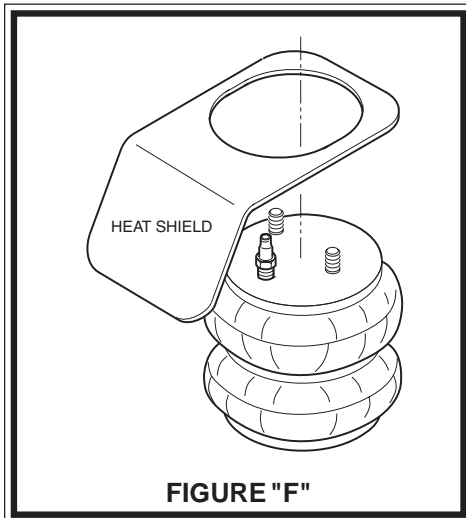

FIGURE "F"

STEP 7 - CHECK THE AIR SYSTEM

Once the inflation valves are installed, inflate the air springs and check the fittings for air leaks with an applied solution of soap and water. If a leak is detected at a tubing connection, check to make sure that the tube is cut as square as possible and that it is pushed completely into the fitting. The tubing can easily be removed from the fittings. First, release the air pressure from the system. Push the collar towards the body of the fitting and pull out the tube. If a leak is detected where the brass straight fitting screws into the air spring, remove the tubing and screw the brass fitting into the spring one additional turn or until the leak stops. Reinsert the tubing and inflate the air springs and check for leaks as noted above.

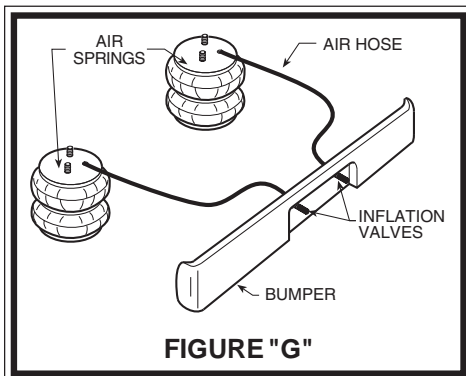

FIGURE "G"

STEP 8 - COMPLETION

Reattach the negative battery cable and remove the wheel chocks from the front wheels. Before proceeding, check once again to be sure you have proper clearance around the air springs. With a load on your vehicle and the air helper springs inflated, you must have at least 1/2" clearance around the air springs. As a general rule, the air helper springs will support approximately 40 lbs. of load for each P.S.I. of inflation pressure (per pair). For example, 50 P.S.I. of inflation pressure will support a load of 2000 lbs. per pair of air helper springs. *FOR BEST RIDE* use only enough air pressure in the air helper springs to level the vehicle when viewed from the side (front to rear). This amount will vary depending on the load, location of load, condition of existing suspension and personal preference.

NOTE:

Too much air pressure in the helper springs will result in a firmer ride, while too little air pressure will allow the air helper spring to bottom out over rough conditions. Too little air pressure will also not provide the improvement in handling that is possible. ***TO PREVENT POSSIBLE DAMAGE MAINTAIN A MINIMUM OF 5 P.S.I. IN THE AIR HELPER SPRINGS AT ALL TIMES.***

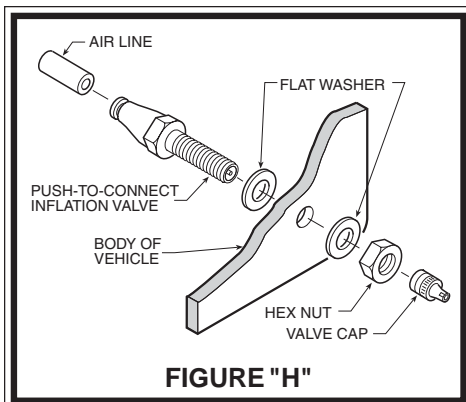

FIGURE "H"

NOTE:	
MIN PRESSURE	5 PSI
MAX PRESSURE (LOADED)	100 PSI

NOTE: Once the air helper springs are installed, it is recommended that the vehicle not be lifted by the frame, as over-extension may occur, resulting in damage to the air springs. However, should it become necessary to raise the vehicle by the frame, deflate both air helper springs completely.