

**TO BE USED ON A CAB AND CHASSIS TRUCK ONLY. DO NOT USE ON A PICKUP TRUCK.**

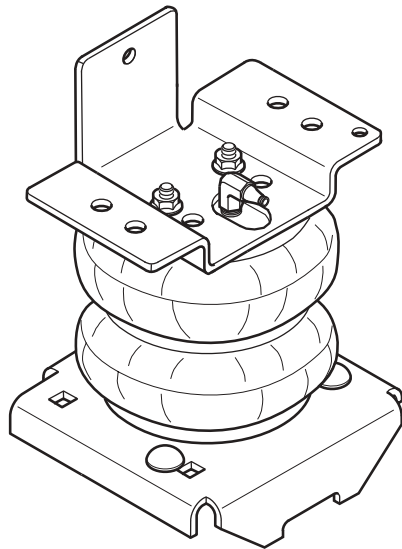

**WARNING:**

Do not inflate this assembly when it is unrestricted. The assembly must be restricted by the suspension or other adequate structure. Do not inflate beyond 100 psi. Improper use or over inflation may cause property damage or severe personal injury.

**INSTALLATION INSTRUCTIONS**

Congratulations - your new Air Helper Springs are quality products capable of improving the handling and comfort of your vehicle. As with all products, proper installation is the key to obtaining all of the benefits your kit is capable of delivering. Please take a few minutes to read through the instructions to identify the components and learn where and how they are used. It is a good idea to start by comparing the parts in your kit with the parts list below.

The heart of the air spring kit is, of course, the air helper springs. Remember that the air helper springs must flex and expand during operation, so be sure that there is enough clearance to do so without rubbing against any other part of the vehicle.

Be sure to take all applicable safety precautions during the installation of the kit. The instructions listed in this brochure and the illustrations all show the left, or driver's side of the vehicle. To install the right side assembly simply follow the same procedures.

Your kit includes separate inflation valves and air lines for each air helper spring. This will allow you to level your vehicle from side to side as well as from front to back. If you would rather have a single valve inflation system, your dealer can supply the required "T" fitting.

**IMPORTANT!**

*For your safety and to prevent possible damage to your vehicle, do not exceed the maximum load recommended by the vehicle manufacturer (GVWR). Although your Air Helper Springs are rated at a maximum inflation pressure of 100 psi, this pressure may allow you to carry too great a load on some vehicles. It is best to have your vehicle weighed once it is completely loaded and compare that weight to the maximum allowed. Check your vehicle owner's manual or data plate on driver side door for maximum loads listed for your vehicle.*

*When inflating your Air Helper Springs, add air pressure in small quantities, checking pressure frequently during inflation. The air spring requires much less air volume than a tire and, therefore, inflates much quicker.*

**TOOLS REQUIRED**

- 15 mm END WRENCH
- (2) 9/16" END WRENCHES
- (2) 1/2" END WRENCHES
- UTILITY KNIFE
- 3/8" SOCKET RATCHET
- 1/8" DRILL BIT
- 5/16" DRILL BIT
- ELECTRIC DRILL

**PARTS LIST**

AIR SPRING	6781	2	3/8"-16 X 1-1/2" HEX BOLT	4
UPPER BRACKET	5295	2	3/8"-16 FLANGE NUT	12
LOWER BRACKET	5300	2	3/8"-16 X 3/4" FLANGE LOCK	2
NUT PLATE BRACKET	5299	2	3/8"-16 X 7" CARRIAGE BOLT	4
18 ft. TUBING	0938	1	3/8" FLAT WASHER	4
PUSH-TO-CONNECT			5/16" FLAT WASHER	4
INFLATION VALVE	3032	2	1/4"-14 X 1 SELF-TAPPING SCREW	2
PUSH-TO-CONNECT			M16 X 2.0 LOCK NUT	4
ELBOW	3031	2	NYLON TIE WRAP	7
THERMAL SLEEVE	0899	2	CAUTION TAG	2

KIT TO FRAME ASSEMBLY

FIGURE "A"

**NOTE:** Both illustrations are of the left, or drivers side, of the truck. Refer to step 3 for the proper lower bracket alignment.

KIT ASSEMBLY

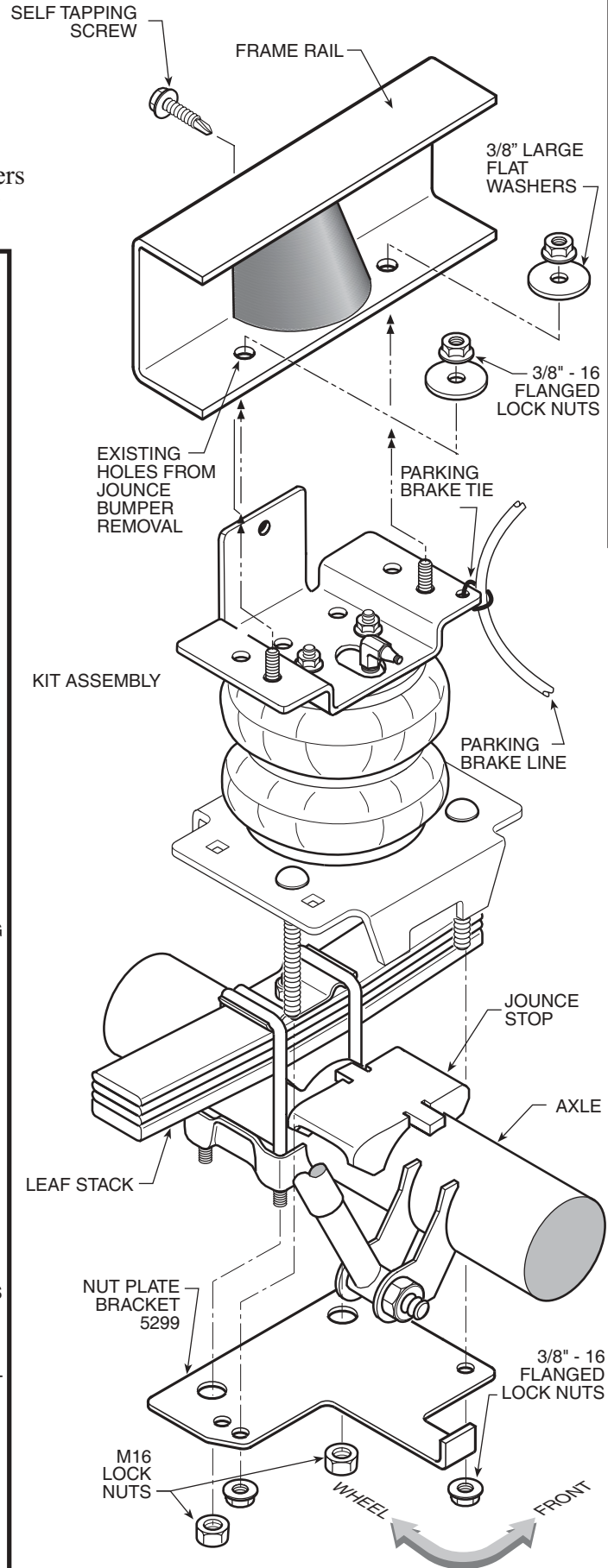
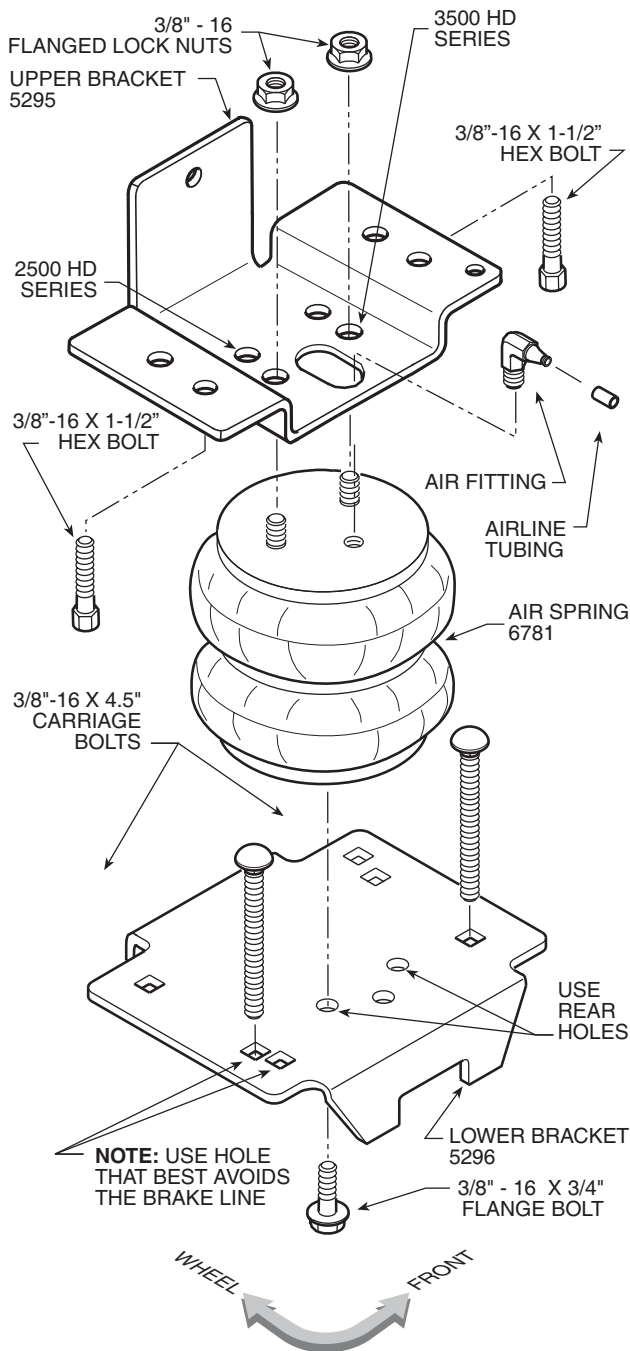

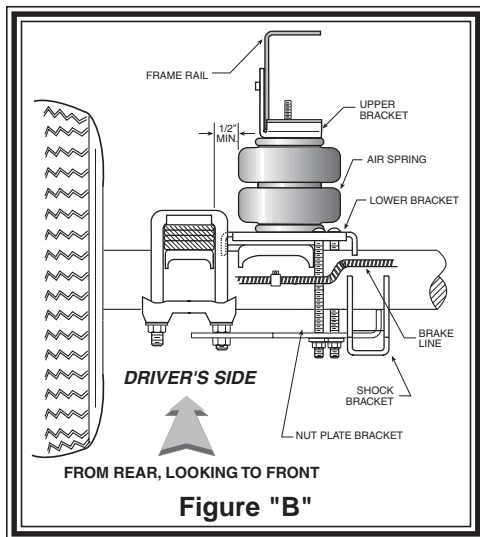

Figure "B"

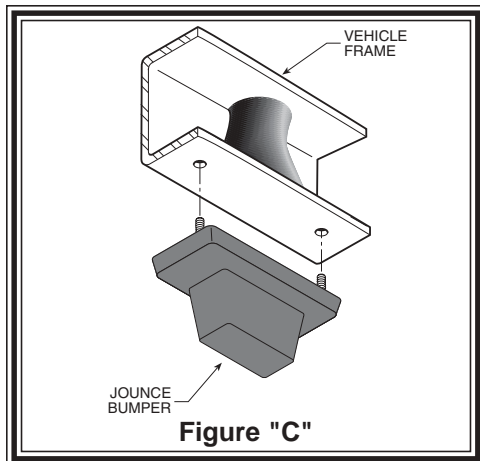

Figure "C"

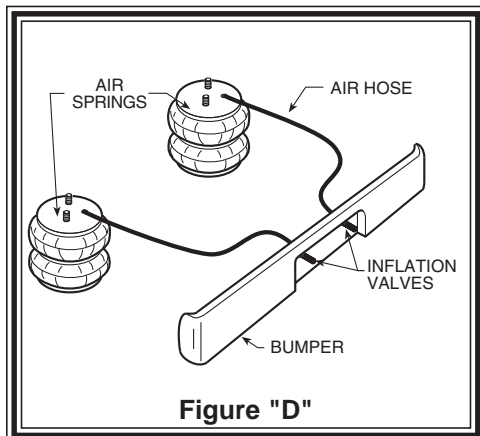

Figure "D"

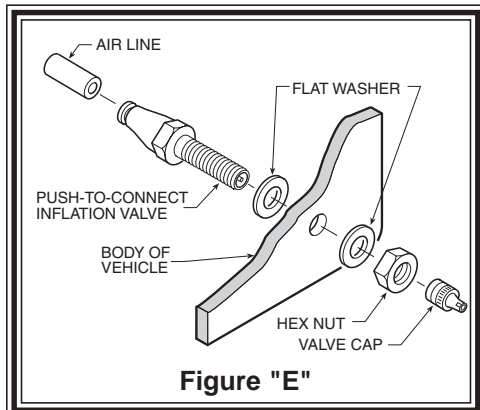

Figure "E"

**NOTE:**

Please read through this manual completely before installing the air spring kit to your vehicle. A heat shield is required on the exhaust side of the vehicle.

**STEP 1 - PREPARE THE VEHICLE**

With the vehicle on a solid, level surface chock the front wheels. Remove the negative battery cable. Remove the jounce bumper located under the frame rail, *see Figure "C"*. The jounce bumpers and nuts will not be reused with this kit.

**STEP 2 - PRE-ASSEMBLE THE KIT**

Select one air helper spring from your kit. Use the mounting holes closest to the outside of the vehicle for the 2500 series truck and use the other mounting holes for the 3500 series truck, *see Figure "A"*. Install the upper bracket by inserting the air helper spring studs into the holes, use two 3/8" - 16 lock nuts to secure the bracket to the air spring, *see Figure "A"*. Install the elbow fitting into the air spring through the large access hole in the upper bracket. Tighten the air fitting securely to engage the orange thread sealant. Position the fitting to point to the anticipated location of the air inflation valves, *see Figure "A" & "D"*. Place the 3/8"-16 x 4.5" carriage bolts into their designated holes and then fasten the lower bracket to the air helper spring using a 3/8"-16 x 3/4" flange hex bolt, *see Figure "A"*.

**STEP 3 - INSTALLING THE ASSEMBLY TO THE VEHICLE**

Place the assembly on the top of the driver's side axle housing, *see Figures "A" & "B"*. Using the existing jounce bumper holes, install the upper bracket onto the frame with 3/8"-16 x 1-1/2" bolts, large flat washers, and 3/8"-16 lock nuts. The 3/8"-16 x 1-1/2" bolts will be facing upward with the washers and nuts on the inside of the frame rail, *see Figure "A"*. The upper bracket will also be attached to the outside of the frame rail. Using the existing hole in the upper bracket as a template, drill a 1/8" pilot hole in the side of the frame rail to ease the insertion of the 1/4" x 1" self-tapping screw, *see Figure "A" & "B"*. **On the drivers side only, the parking brake line will need to be tie-wrapped to the upper bracket, *see Figure "A" & "B"*.** Position the nut plate bracket on the leaf spring retainer below the axle. Two of the U-bolt studs should protrude through the holes in the nut plate bracket. Attach the nut plate bracket to the U-bolts with the provided M16 x 2.0 hex nuts. Attach the lower bracket to the axle using the nut plate bracket and 3/8"-16 flange lock nuts, *see Figure "A"* for bolt location. The lower bracket should fit without altering the brake lines. If the brake lines are touching the bracket, it may be necessary to reposition the line to avoid contact with the bracket. Once the assembly is in place, you must have a minimum of 1/2" clearance around the air spring for proper operation, *see Figure "B"*.

**STEP 4 - INSTALLATION OF THE PASSENGER'S SIDE ASSEMBLY**

Follow steps 1-3 with reverse orientations for assembly and installation of the passenger's side assembly.

**STEP 5 - INSTALL THE AIR LINE AND INFLATION VALVE**

Uncoil the airline tubing and cut it into two equal lengths. **DO NOT FOLD OR KINK THE AIRLINE TUBING.** Try to make the cut as square as possible. Insert one end of the airline tubing into the air fitting installed in the top of the air helper spring. Push the airline tubing into the fitting as far as possible *see Figure "A"*.

## **STEP 5 - CONTINUED**

Select a location on the vehicle for the air inflation valves. The location can be on the bumper or the body of the vehicle, as long as it is in a protected location so the valve will not be damaged, but maintain accessibility for the air chuck *see Figure "D"*. Drill a 5/16" hole and install the air inflation valve using two 5/16" flat washers per valve as supports *see Figure "E"*. Run the airline tubing from the air helper spring to the valve, routing it to avoid direct heat from the engine, exhaust pipe, and away from sharp edges. Thermal sleeves have been provided for these conditions. The airline tubing should not be bent or curved sharply as it may buckle. Secure the airline tubing in place with the nylon ties provided. Push the end of the airline tubing into the inflation valve as illustrated *see Figure "E"*.

## **STEP 6 - CHECK THE AIR SYSTEM**

Once the inflation valves are installed, inflate the air helper springs to 70 *psi* and check the fittings for air leaks. Using a spray bottle, apply a solution of soap and water to the fittings. If a leak is detected at a airline tubing connection then check to make sure that the airline tube is cut as square as possible and that it is pushed completely into the fitting. The airline tubing can easily be removed from the fittings by exhausting all the pressure in the air springs and then pushing the collar towards the body of the fitting and then, with a gentle pull, remove the airline tubing. If a leak is detected where the air fitting screws into the spring, screw the air fitting into the air spring until the leak stops. Reinstall the tubing and reinflate the air springs and check for leaks as noted above.

This now completes the installation. Reattach the negative battery cable and remove the wheel chocks from the front wheels. Before proceeding, check once again to be sure you have proper clearance around the air springs. With a load on your vehicle and the air helper springs inflated, you must have at least 1/2" clearance around the air springs. As a general rule, the air helper springs will support approximately 50 lbs. of load for each *psi* of inflation pressure (per pair). For example, 50 *psi* of inflation pressure will support a load of 2500 lbs. per pair of air helper springs. *FOR BEST RIDE* use only enough air pressure in the air helper springs to level the vehicle when viewed from the side (front to rear). This amount will vary depending on the load, location of load, condition of existing suspension and personal preference.

### **NOTE:**

Too much air pressure in the air helper springs will result in a firmer ride, while too little air pressure will allow the air helper spring to bottom out over rough conditions. Too little air pressure will not provide the improvement in handling that is possible. ***TO PREVENT POSSIBLE DAMAGE MAINTAIN A MINIMUM OF 5 *psi* IN THE AIR HELPER SPRINGS AT ALL TIMES.***

### **NOTE:**

Once the air helper springs are installed, it is recommended that the vehicle not be lifted by the frame, as over-extension may occur, resulting in damage to the air helper springs. However, should it become necessary to raise the vehicle by the frame, deflate both air helper springs completely.

