

INSTALLATION INSTRUCTIONS

Congratulations - your new Air Helper Springs are quality products capable of improving the handling and comfort of your vehicle. As with all products, proper installation is the key to obtaining all of the benefits your kit is capable of delivering. Please take a few minutes to read through the instructions to identify the components and learn where and how they are used. It is a good idea to start by comparing the parts in your kit with the parts list below.

The heart of the air spring kit is, of course, the air helper springs. Remember that the air helper springs must flex and expand during operation, so be sure that there is enough clearance to do so without rubbing against any other part of the vehicle.

Be sure to take all applicable safety precautions during the installation of the kit. The instructions listed in this brochure and the illustrations all show the left, or driver's side of the vehicle. To install the right side assembly simply follow the same procedures.

WARNING:

Do not inflate this assembly when it is unrestricted. The assembly must be restricted by the suspension or other adequate structure. Once installed, do not inflate beyond 100 psi. Improper use or over inflation may cause property damage or severe personal injury.

Your kit includes separate inflation valves and air lines for each air helper spring. This will allow you to level your vehicle from side to side as well as from front to back. If you would rather have a single valve inflation system, your dealer can supply the required "T" fitting.

IMPORTANT!

For your safety and to prevent possible damage to your vehicle, do not exceed the maximum load recommended by the vehicle manufacturer (GVWR). Although your Air Helper Springs are rated at a maximum inflation pressure of 100 psi, this pressure may allow you to carry too great a load on some vehicles. It is best to have your vehicle weighed once it is completely loaded and compare that weight to the maximum allowed. Check your vehicle owner's manual or data plate on driver side door for maximum loads listed for your vehicle.

When inflating your Air Helper Springs, add air pressure in small quantities, checking pressure frequently during inflation. The air spring requires much less air volume than a tire and, therefore, inflates much quicker.

TOOLS REQUIRED

- (2) 9/16" END WRENCHES
- (2) 1/2" END WRENCHES
- UTILITY KNIFE
- ELECTRIC DRILL
- 5/16" DRILL BIT

PARTS LIST

AIR SPRING	6781	2	3/8"-16 X 1" HEX BOLT	8
UPPER BRACKET	5302	2	3/8"-16 X 1-1/2" HEX BOLT	4
LOWER BRACKET	5304	2	3/8"-16 FLANGE LOCK NUT	26
LOWER BRACE	5303	2	3/8"-16 X 3/4" FLANGE BOLT	2
BRACKET STRAP	1163	2	3/8"-16 X 3" CARRIAGE BOLT	4
BAIL CLAMP	3077	2	3/8"-16 X 1-1/2" CARRIAGE BOLT	2
18 ft. TUBING	0938	1	3/8" FLAT WASHER	3
PUSH-TO-CONNECT			5/16" FLAT WASHER	4
INFLATION VALVE	3032	2	NYLON TIE WRAP	6
1/4 NPT STRAIGHT FITTING	3046	2	CAUTION TAG	2
THERMAL SLEEVE	0899	2		

2251

NOTE: Both illustrations are of the left, or driver's side of the vehicle. Reverse any orientations when installing the right, or passenger's side assembly.

**K
I
T
A
S
S
E
M
B
L
Y**

KIT TO FRAME ASSEMBLY

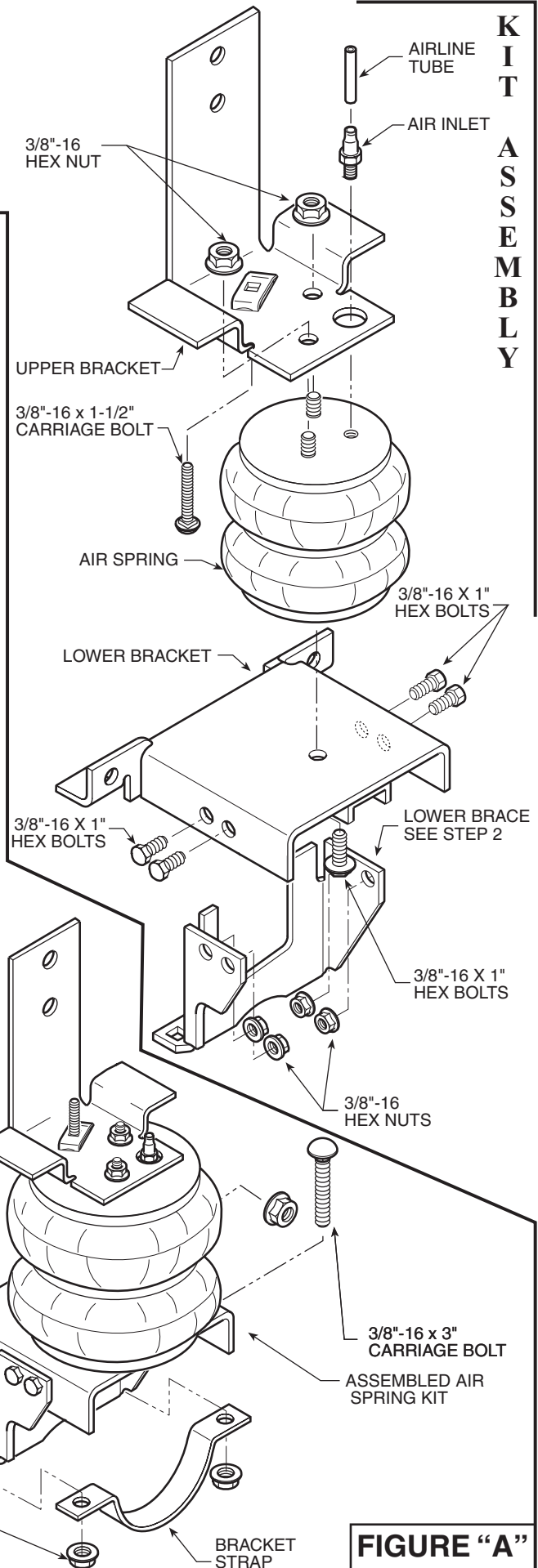
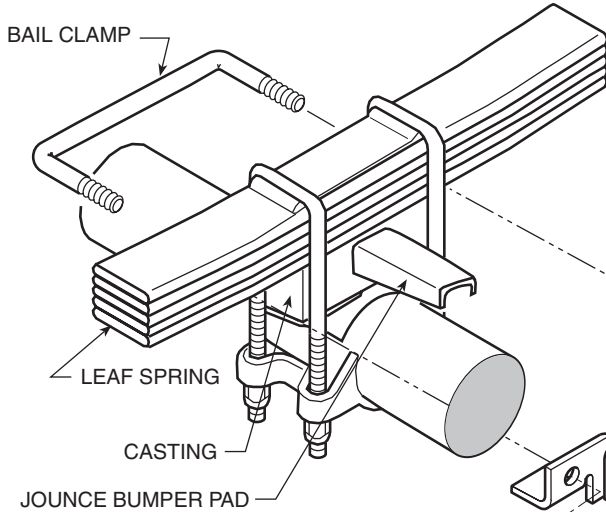
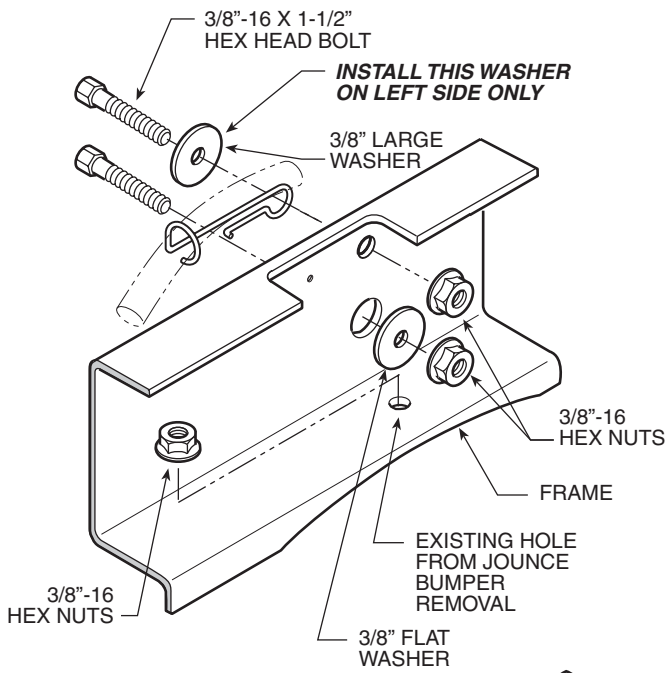

FIGURE "A"

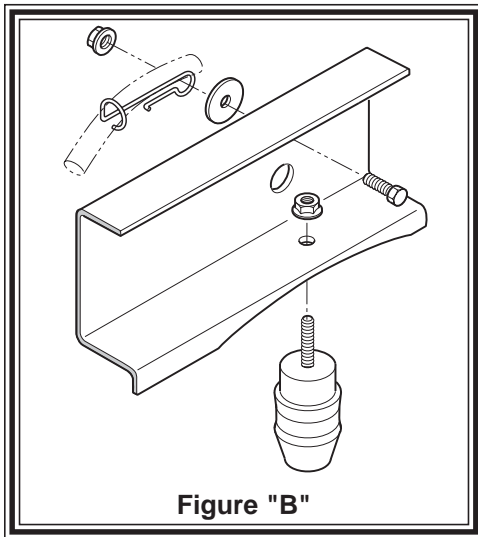

Figure "B"

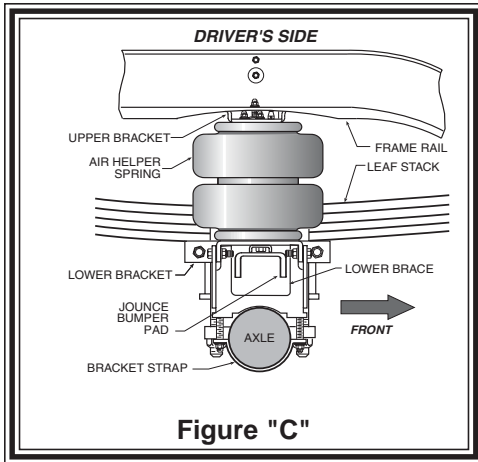

Figure "C"

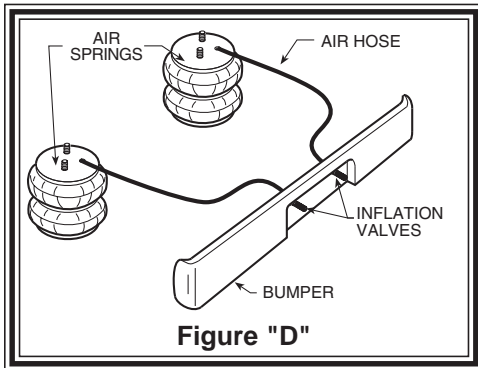

Figure "D"

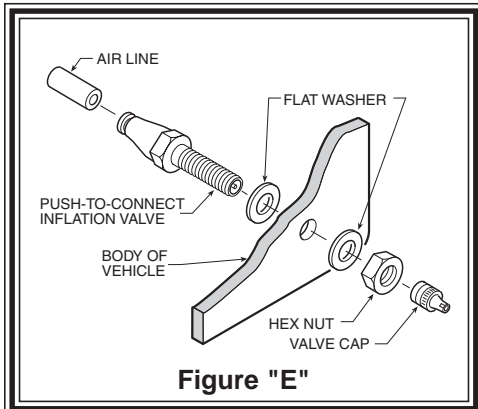

Figure "E"

STEP 1 - PREPARE THE VEHICLE

Place the vehicle on a solid level surface. Remove negative battery cable. Take necessary safety precautions such as using wheel chocks when working on your vehicle. Remove the jounce bumpers and the driver side brake line clip, bolt, and nut as shown in *Figure "B"*. This vehicle does not have to be jacked up to install the kit.

STEP 2 - PRE-ASSEMBLE THE KIT

Select one air spring and one upper bracket from your kit. Insert the 1-1/2" carriage bolt upward into square space in upper bracket. Attach the upper bracket to the air spring using the 3/8"-16 flange lock nuts. Install the brass air fitting into the air entrance hole and tighten securely to engage the orange thread sealant to ensure proper seal.

LOWER BRACKET ASSEMBLY

Select one lower bracket and one lower brace from your kit. Fasten the lower brace to the lower bracket using the 3/8"-16 x 1" hex bolts and lock nuts as shown in *Figure "A"*. Assemble the lower bracket assembly to the air helper spring using the 3/8"-16 x 3/4" flanged hex bolt. Before tightening the 3/8"-16 flanged hex bolt, rotate the air spring so that the outside vertical edge of the upper bracket is parallel with the front face of the lower bracket and brace assembly, *see Figure "A"*.

STEP 3 - INSTALLING THE ASSEMBLY TO THE VEHICLE

Place the assembly on the vehicle by installing the upper bracket so that it lays against the outside of the frame rail. Insert the carriage bolt in the upper bracket to the existing hole in the frame rail from the jounce bumper removal. Attach with a 3/8"-16 flange lock nut. The lower brace will sit on the axle, and the lower bracket will rest on the jounce bumper pad, *refer to Figure "A" and "C"*. Push the lower bracket toward the leaf spring stack until it rests next to the leaf spring "U" bolts.

Attach the upper bracket to the frame rail using the 2 existing holes in the frame rail and the 3/8"-16 x 1-1/2" hex bolts, 3/8"-16 flange lock nuts, and 3/8" flat washers (flat washer used only for the larger hole in frame). NOTE: The break line clip shown in *Figure "A" and "B"* exists only on the driver's side of the vehicle. On the driver's side, the bolt will reattach the clip outside of the upper bracket as shown. The 3/8" flat washer on the outside of the frame rail is used only on the driver's side to hold the brake line clip in place. No washer is used on the outside of the passenger's side frame rail.

Install the bail clamp around the casting as shown in *Figure "A"*. Insert the bail clamp through the holes in the lower bracket as shown in *Figure "A"*. Install 3/8"-16 flange lock nuts and draw the lower bracket next to the leaf spring "U" bolts. Using the 3/8"-16 x 3" carriage bolts attach the bracket straps to the lower brace making sure the bracket straps are securing the kit assembly to the axle, *refer to Figure "C"*.

STEP 4 - INSTALLATION OF THE PASSENGER'S SIDE ASSEMBLY

Follow steps 1-3 with reverse orientations for assembly and installation of the passenger's side assembly. (Note that on the right side (passenger side), the assembly will sit close to the heat shield located on the front of the axle.)

STEP 5 - INSTALL THE AIR LINE AND INFLATION VALVE

Uncoil the airline tubing and cut it into two equal lengths. **DO NOT FOLD OR KINK THE AIRLINE TUBING.** Try to make the cut as square as possible. Insert one end of the airline tubing into the air fitting installed in the top of the air helper spring. Push the airline tubing into the fitting as far as possible, *refer*

to Figure "A".

Select a location on the vehicle for the air inflation valves. The location can be on the bumper or the body of the vehicle, as long as it is in a protected location so the valve will not be damaged, but maintain accessibility for the air chuck *as shown in Figure "D"*. Drill a 5/16" hole and install the air inflation valve using two 5/16" flat washers per valve as supports *as shown in Figure "E"*. Run the airline tubing from the air helper spring to the valve, routing it to avoid direct heat from the engine, exhaust pipe, and away from sharp edges. Thermal sleeves have been provided for these conditions. The airline tubing should not be bent or curved sharply as it may buckle. Secure the airline tubing in place with the nylon ties provided. Push the end of the airline tubing into the inflation valve as illustrated *as shown in Figure "E"*.

STEP 6 - CHECK THE AIR SYSTEM

Once the inflation valves are installed, inflate the air helper springs to 70 psi and check the fittings for air leaks. Using a spray bottle, apply a solution of soap and water to the fittings. If a leak is detected at an airline tubing connection then check to make sure that the airline tube is cut as square as possible and that it is pushed completely into the fitting. The airline tubing can easily be removed from the fittings by exhausting all the pressure in the air springs and then pushing the collar towards the body of the fitting and then, while still holding the collar against the body, gently pull on the airline tubing to remove. If a leak is detected where the air fitting screws into the spring, deflate the air springs and remove the tubing, then screw the air fitting into the air spring one additional turn or until the leak stops. Reinstall the tubing and reinflate the air springs and check for leaks as noted above.

NOTE:

Too much air pressure in the air helper springs will result in a firmer ride, while too little air pressure will allow the air helper spring to bottom out over rough conditions. Too little air pressure will not provide the improvement in handling that is possible. ***TO PREVENT POSSIBLE DAMAGE MAINTAIN A MINIMUM OF 5 psi IN THE AIR HELPER SPRINGS AT ALL TIMES.***

NOTE:

Once the air helper springs are installed, it is recommended that the vehicle not be lifted by the frame, as over-extension may occur, resulting in damage to the air helper springs. However, should it become necessary to raise the vehicle by the frame, deflate both air helper springs completely.



www.ride-rite.com

**FIRESTONE INDUSTRIAL PRODUCTS
12650 HAMILTON CROSSING BOULEVARD
CARMEL, IN 46032**