

INSTALLATION INSTRUCTIONS

Congratulations - your new Air Helper Springs are quality products capable of improving the handling and comfort of your vehicle. As with all products, proper installation is the key to obtaining all of the benefits your kit is capable of delivering. Please take a few minutes to read through the instructions to identify the components and learn where and how they are used. It is a good idea to start by comparing the parts in your kit with the parts list below.

The heart of the air spring kit is, of course, the air helper springs. Remember that the air helper springs must flex and expand during operation, so be sure that there is enough clearance to do so without rubbing against any other part of the vehicle.

Be sure to take all applicable safety precautions during the installation of the kit. The instructions listed in this brochure and the illustrations all show the left, or driver's side of the vehicle. To install the right side assembly simply follow the same procedures.

WARNING:

Do not inflate this assembly when it is unrestricted. The assembly must be restricted by the suspension or other adequate structure. Do not inflate beyond 100 psi. Improper use or over inflation may cause property damage or severe personal injury.

This kit includes inflation valves and air lines for each air spring. This will allow you to compensate for unbalanced loads. If you would rather have a single inflation valve system to provide equal pressure to both air springs, your dealer can supply the optional "T" fitting.

IMPORTANT!

For your safety and to prevent possible damage to your vehicle, do not exceed the maximum load recommended by the vehicle manufacturer (GVWR). Although your Air Helper Springs are rated at a maximum inflation pressure of 100 psi, this pressure may allow you to carry too great a load on some vehicles. It is best to have your vehicle weighed once it is completely loaded and compare that weight to the maximum allowed. Check your vehicle owner's manual or data plate on driver side door for maximum loads listed for your vehicle.

When inflating your Air Helper Springs, add air pressure in small quantities, checking pressure frequently during inflation. The air spring requires much less air volume than a tire and, therefore, inflates much quicker.

PARTS LIST

AIR SPRING	6397	2	5/16" FLAT WASHER	4
UPPER BRACKET	5451	2	18 ft. TUBING	0938 1
LOWER BRACKET	5452	2	PUSH-TO-CONNECT	
AXLE STRAP	0530	4	INFLATION VALVE	3032 2
3/8"-16 X 5/8" FLAT HEAD BOLT		2	PUSH-TO-CONNECT	
10MM X 30MM FLAT HEAD BOLT		4	ELBOW FITTING	3048 2
3/8"-16 X FLANGE LOCK NUT		8	THERMAL SLEEVE	0899 2
3/8"-16 X 2 1/2" CARRIAGE BOLT		8	NYLON TIE WRAP	7
5/8"-18 NYLOCK NUT		2	CAUTION TAG	2

UPPER BRACKET INSTALLATION

FIGURE "A"

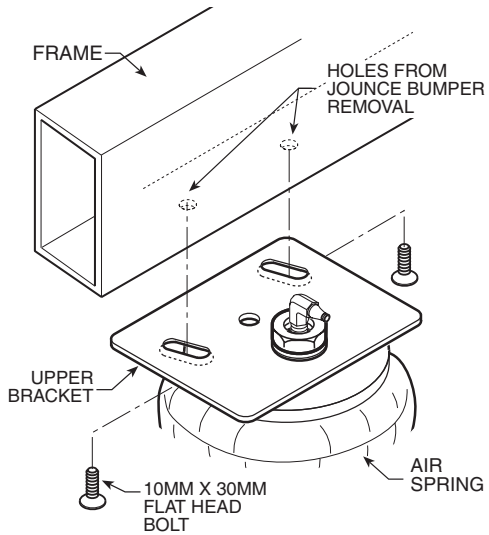

4X4 AND Z71 2WD

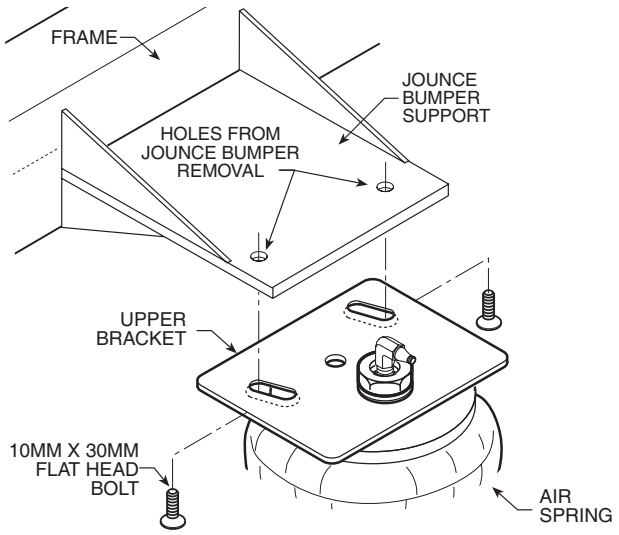

2WD, NON-Z71

KIT ASSEMBLY

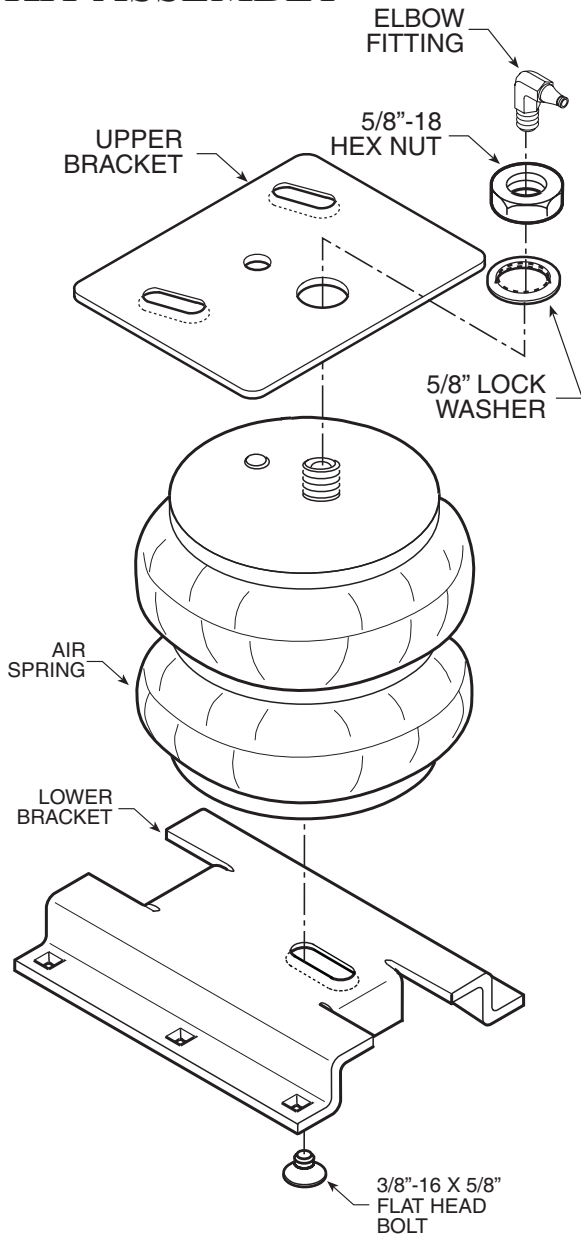

NOTE: UPPER & LOWER BRACKET INSTALLATION DIFFERS BETWEEN 2WD AND 4X4 & Z71. PLEASE SEE INSTRUCTIONS.

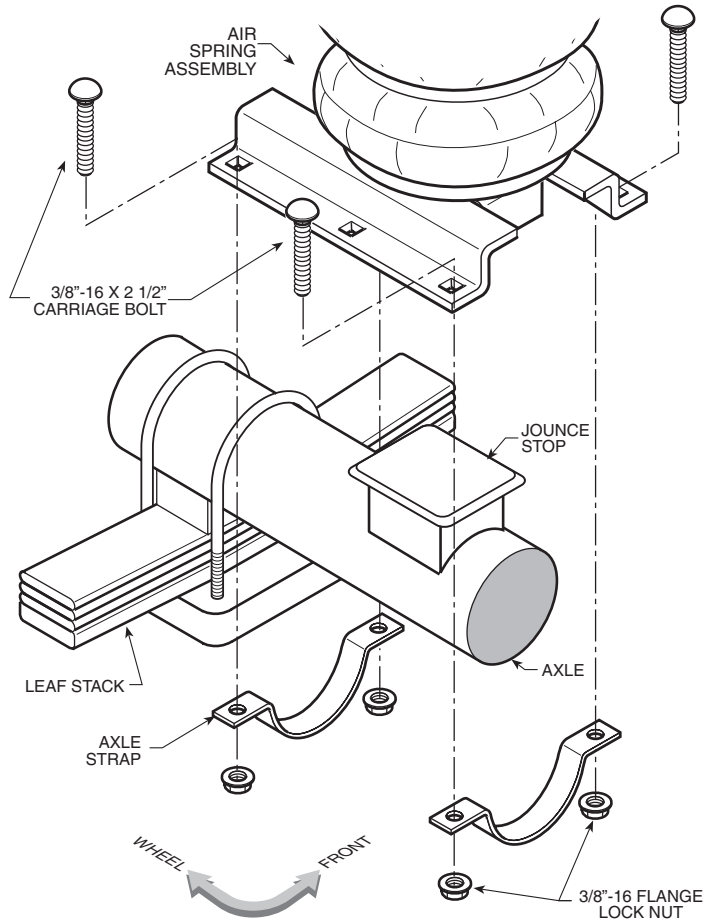

LOWER BRACKET INSTALLATION

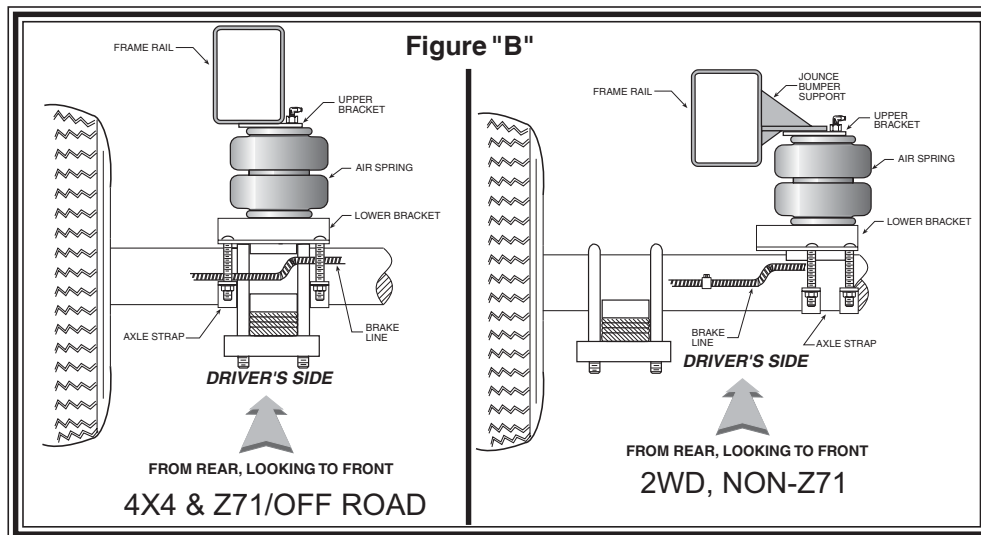

NOTE:

Please read through this manual completely before installing the air spring kit to your vehicle. All illustrations reference the driver's or left side of the vehicle. Reverse all orientations for the passenger's or right side.

STEP 1 - PREPARE THE VEHICLE

Remove the jounce bumper located under the frame rail or on the jounce bumper support. The jounce bumpers and bolts will not be reused with this kit.

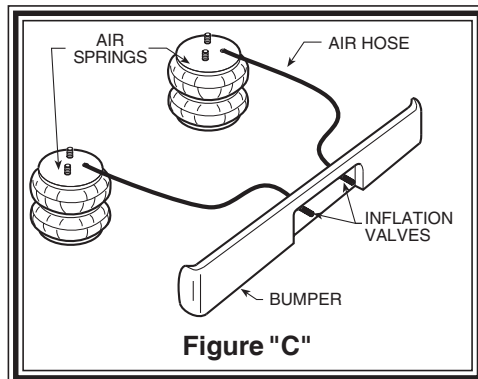

STEP 2 - PRE-ASSEMBLE THE KIT

Select one air helper spring from your kit. Attach the lower bracket to the air spring using the 3/8" - 16 x 5/8 flat head bolt. *See Figure "A"*. Attach the upper bracket to the air spring with a 5/8" nylock nut. *See Figure "A"*. The combination stud will use the larger diameter hole and the alignment "button" will use the smaller diameter hole. Install the elbow fitting into the air spring. Tighten the air fitting securely to engage the orange thread sealant. Position the fitting to point to the anticipated location of the air inflation valves, *see Figure "A" & "C"*.

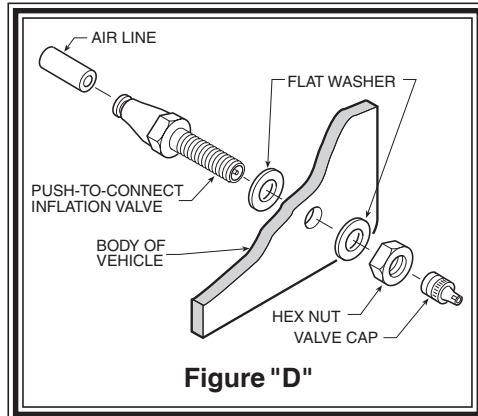

STEP 3 - INSTALLING THE ASSEMBLY TO THE VEHICLE

Place the assembly on the jounce stop of the driver's side, *see Figures "A" & "B"*. Using the existing jounce bumper holes, install the upper bracket onto the frame with 10MM x 30MM flat head bolts, *see Figure "A"*. Attach the lower bracket to the axle using the axle strap or straps, 3/8" - 16 x 2 1/2" carriage bolts, and 3/8" - 16 flange lock nuts, *see Figure "A" & "B"*. Once the assembly is in place, you must have a minimum of 1/2" clearance around the air spring.

STEP 4 - PASSENGER'S SIDE INSTALLATION

Follow steps 1-3 with reverse orientations for assembly and installation of the passenger's side.

STEP 5 - INSTALL THE AIR LINE AND INFLATION VALVE

Uncoil the airline tubing and cut it into two equal lengths. *DO NOT FOLD OR KINK THE AIRLINE TUBING*. Try to make the cut as square as possible. Insert one end of the airline tubing into the air fitting installed in the top of the air helper spring. Push the airline tubing into the fitting as far as possible *see Figure "A"*. Select a location on the vehicle for the air inflation valves. The location can be on the bumper or the body of the vehicle, as long as it is in a protected location so the valve will not be damaged, but maintain accessibility for the air chuck, *see Figure "C"*. Drill a 5/16" hole and install the air inflation valve using two 5/16" flat washers per valve as supports, *see Figure "D"*.

Run the airline tubing from the air helper spring to the valve, routing it to avoid direct heat from the engine, exhaust pipe, and away from sharp edges. Thermal sleeves have been provided for these conditions.

