



CHEVY/GMC

SuperRail Mounting Kit

#4423



Installation Instructions

SPECIFICATIONS

- Fits 2007-2019 Chevy/GMC 1500 Light Duty Truck
 - New Body Style
 - 6-1/2' bed
 - Hitch located 3/4" ahead of axle
U.S. Pat. No. 6,065,766

Table of Contents

Important	3
Mounting Hardware Parts Identification	4
Parts List	5
Installation – Marking the Bed for Drilling	6
Truck Bed Layout	7
Mounting Bracket Installation	
Part 1 – Bracket Placement & Bed Hole Locations	8-9
Hitch Assembly Exploded View	10
Part 2 – Drilling the Bed & Bracket Installation	11
Part 3 – Hitch Alignment	12
Part 4 – Final Installation Procedures	12

IMPORTANT

DO NOT OPERATE HITCH UNTIL YOU READ THIS SECTION!

1. The SuperGlide hitch was designed to allow the Turntable Cam Arm Assembly to “glide” along two metal tubes, called the Way Tubes. Since it’s release in 1998, we have made several advancements in the design, strength, and durability of these components. The Lubrication section of your Owners Manual spans several product releases and design changes. It is *imperative* that you read each section and determine which SuperGlide hitch you purchased, and how to care for it. There have been three major lubrication changes to the SuperGlide hitch:
 - Prior to April 2008, Way Tubes were assembled with either a conventional, quality grade grease or none at all
 - In April 2008, we started coating the Way Tubes with a graphite-based spray lubricant called SlipPlate™
 - November 2009 brings a new innovation from PullRite Towing Systems with the use of plastics. The Turntable Cam Arm Assembly is now equipped with Plastic Wear Plates; see Owners Manual for details (not available for #3600 models)

Depending on when your hitch was manufactured, the Way Tubes of your new SuperGlide hitch will meet one of the above criteria. Each application listed requires some level of maintenance, so it is important that you read the following instructions carefully for the correct lubrication instructions.

Failure to properly lubricate the Way Tubes, as directed in this section, will eventually cause galling between the metals of the Way Tubes and Cam Arm Assembly, which will result in hitch failure. Destruction of various hitch parts is also likely, as well as truck and/or trailer damage, and will not be covered under the Manufacturer’s Warranty.

2. **THE TRAILER’S KING PIN BOX MUST BE EQUIPPED WITH A CAPTURE PLATE (UNIVERSAL OR QUICK CONNECT) TO ALLOW THE HITCH TO FUNCTION (MUST BE PURCHASED SEPARATELY). NOTE: IF YOU HAVE PURCHASED A QUICK CONNECT CAPTURE PLATE AND DID NOT RECEIVE INSTRUCTIONS, THEY ARE AVAILABLE ONLINE, OR YOU CAN CONTACT PULLRITE CUSTOMER SERVICE AT (800) 443-2307.**
3. Failure to modify the length of the brake away cable that activates the emergency braking of your trailer, may cause the cable to catch on protruding parts of the hitch. Resulting damage will not be covered by the manufacturers warranty.
4. There should be a minimum of 6” between the truck bed rails and the under side of the trailer for side tilt clearance. It is the customers responsibility to adjust the trailer king pin box for the appropriate amount of clearance.

NOTE: Some truck models are being manufactured with higher bed sides, making it necessary to adjust the height of your trailer’s king pin box. If you don’t have enough height adjustment available, PullRite produces a 3” Lift Kit that attaches to the rails of your #3100 (ask for part #3108) or #4100, #3300 and #4400 (ask for part #4408; *rated only for 18K when used with model #4400*) SuperGlide models.
5. Some truck beds have contoured bed sides, making the inside bed measurement narrower. Make certain the trailer’s king pin box does not contact the inside edge of the bed.
6. Trucks with bed liners may need a tall Mounting Post. See “NOTE” under “Drilling the Bed” for further details.
7. It is the installers and customers responsibility to ensure there is proper clearance between the truck and trailer. There should be a minimum of 2” of clearance as the trailer passes the cab. Call PullRite technical support with trailer width, make and year of truck and distance the king pin is from leading edge of the trailer (See “Caution” section, in the SuperGlide Owners Manual, for measuring procedure) at (800) 443-2307.
8. Read these instructions completely and follow them accurately. Should you have any questions, please call Customer Service at (800) 443-2307 prior to installation for assistance. *If you did not receive your Owners Manual, visit us online at www.pullrite.com or call the number above.*
9. The SuperGlide was designed for short bed pickup trucks. The hitch may function in a longer bed truck, but no mounting brackets exist to make the transfer. Some #4100 and #4400 mounting kits may transfer with modification.

MOUNTING HARDWARE PARTS IDENTIFICATION

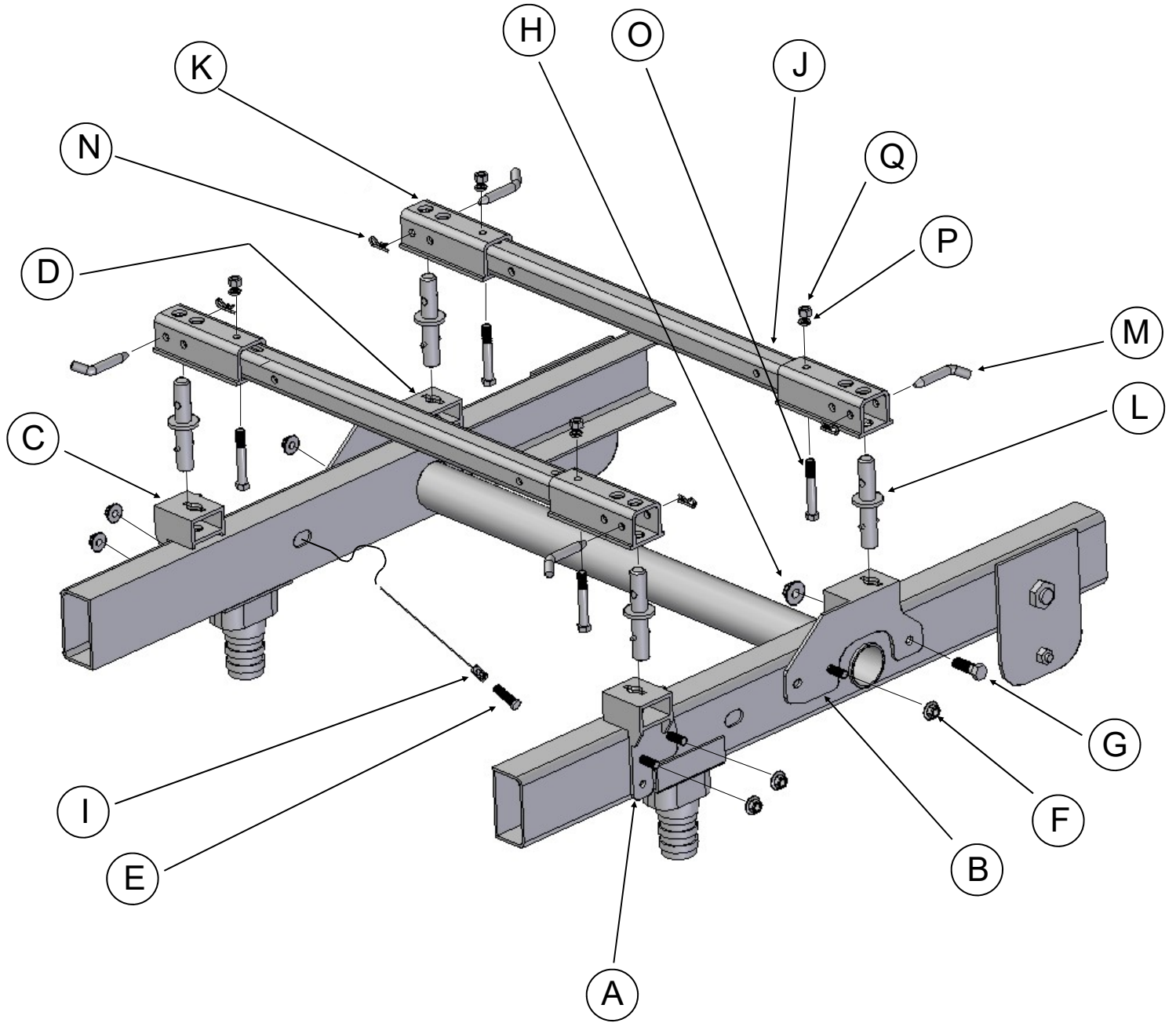

PARTS LIST

#4423 — CHEVY/GMC LD SUPER RAIL MOUNTING KIT			
Description	Part No.	Qty.	Material
MOUNTING BRACKET KIT	4422	1	(See kit contents listed below)
BASE RAIL KIT	3307	1	(See kit contents listed below)

#4422 — MOUNTING BRACKET KIT				
Item	Description	Part No.	Qty.	Material
A	FRONT DRIVER SIDE MOUNTING BRACKET	442201	1	
B	REAR DRIVER SIDE MOUNTING BRACKET	331503	1	
C	FRONT PASSENGER SIDE MOUNTING BRACKET	442202	1	
D	REAR PASSENGER SIDE MOUNTING BRACKET	331504	1	
	MOUNTING BRACKET HARDWARE KIT	442205	1	(See kit contents listed below)

#442205 — MOUNTING BRACKET HARDWARE KIT				
Item	Description	Part No.	Qty.	Material
E	1/2" SPLINE BOLT	98410192	6	1/2" - 13 X 1-1/2" SPLINE BOLT
F	1/2" SERRATED FLANGE NUT	98150201	6	1/2" - 13 SERRATED FLANGE NUT
G	5/8" FRAME BOLTS	98010231	2	5/8"-11 x 1-1/2" HHCS GRD 5
H	5/8"-11 FRAME NUT	98150200	2	5/8"-11 FLANGE NUT
I	BOLT LEADER	98340197	1	1/2" BOLT LEADER

#3307 — BASE RAIL KIT				
Item	Description	Part No.	Qty.	Material
J	BASE RAIL	33070001	2	2" SQ. x 1/4" WALL TUBING
K	BASE RAIL EXTENSION	330702	4	2.5" TUBE ASSEMBLY
L	MOUNTING POST	330701	4	1" ROUND ASSEMBLY
M	BASE RAIL HINGE PIN	08060001	4	1/2" ROUND
N	HITCH PIN CLIP	98410127	4	#3 COTTER PIN
O	BASE RAIL BOLT	98010183	4	1/2" 13x3" HHCS GRD 5
P	BASE RAIL LOCK WASHER	98200142	4	1/2" LOCK WASHER
Q	BASE RAIL HEX NUT	98150153	4	1/2" - 13 HEX NUT

LAYOUT TEMPLATE			
Description	Part No.	Qty. Used	Material
LAYOUT BED TEMPLATE	33150000		ITEM SOLD SEPARATELY

INSTALLATION

Truck Preparation

1. Check part quantities using the Parts List on Page 2.
2. Block vehicle wheels. Some vehicles may require you to raise the rear of the truck in order to make it easier to drill for installing the mounting brackets on the truck frame.
3. You may wish to remove the wheels, to give yourself greater working room.
4. If you have purchased a template, proceed to “Template Method” below; otherwise, begin with the “Layout Method.”

Marking the Bed for Drilling

Layout Method

1. See “Truck Bed Dimension Table” under “Layout Method” on Page 4 for the dimensions. Measure and mark from the back of the bed forward the values for “A” and “B”. Do this at any point on both sides of the bed.
2. Draw a line across the bed from mark to mark.
3. Find the centerline of the bed.
4. Draw a line down the middle of the bed from front to rear.
5. Center the measurement of “C” across the centerline at the front-most line you made in step 2 and mark the measurement on each side (parallel to the centerline).
6. Center the measurement of “D” for the rear most line made in step 2, and again mark the measurement on each side (parallel to the centerline). This will locate the 4 drill holes.

Template Method

1. Lay the Template in the truck bed, centering it from side-to-side, and parallel to the end of the truck bed, using the dimension “X” listed in Truck bed layout dimension table on Page 4.
2. Mark the 4 holes, while making sure the template does not move.

TRUCK BED LAYOUT

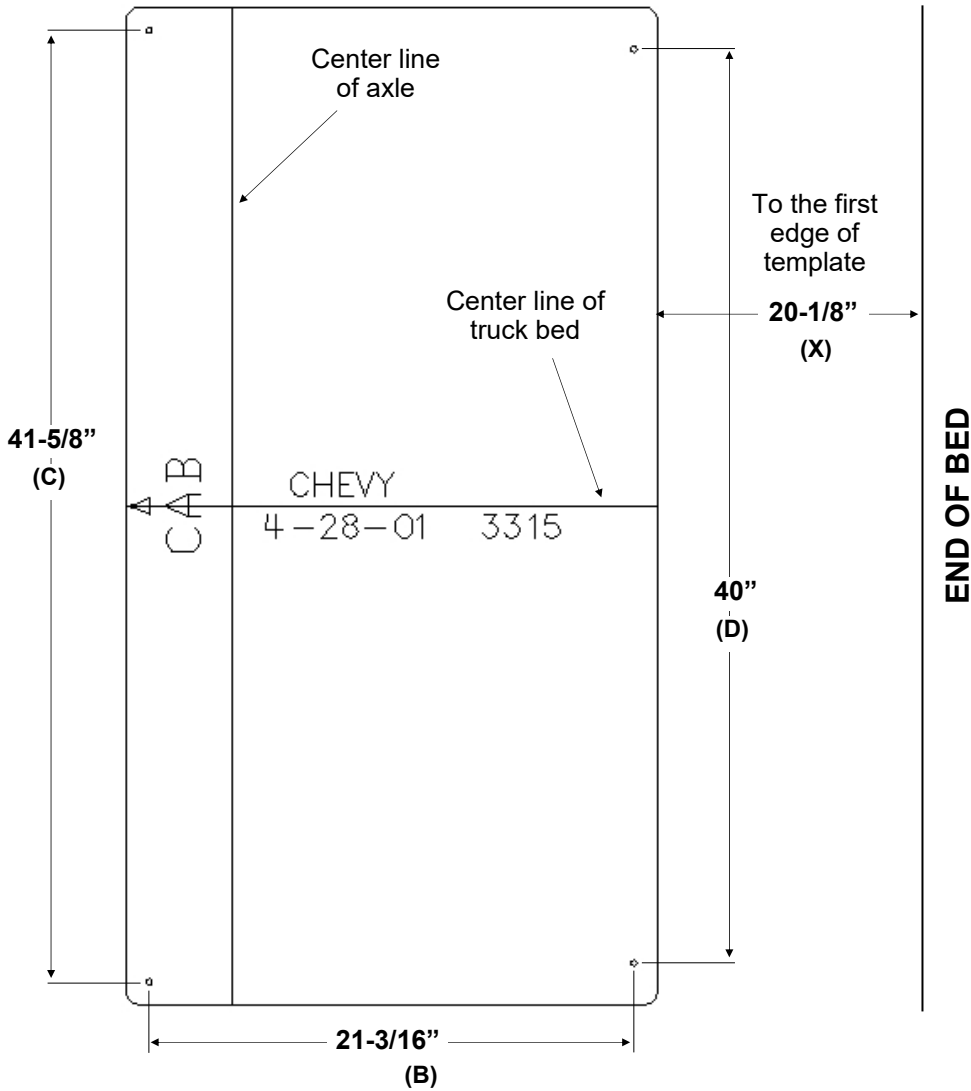

NOTES:

The TEMPLATE should be orientated as shown in the drawing to the left. Notice that the spacing of the forward and rearward facing holes may be different, and can be used to determine the correct orientation of the template. Item "C" in the table below shows the forward facing dimension, and Item "D", the rearward facing dimension. Note also, the information etched into the template — the direction of the cab, the template number and the revision date.

INSTALLATION TIP:

The template has a tendency to move when placed on the slick paint of new truck beds, and it may be helpful to place a small piece of NON-SKID matting, such as "SCOOT-GARD"™ or simply use duct tape on each corner to help keep the template from moving.

Torque Table

3/8" Bolt — 31 ft. lbs.
 1/2" Bolt — 75 ft. lbs.
 5/8" Bolt — 151 ft. lbs.
 3/4" Bolt — 266 ft. lbs.

LAYOUT METHOD

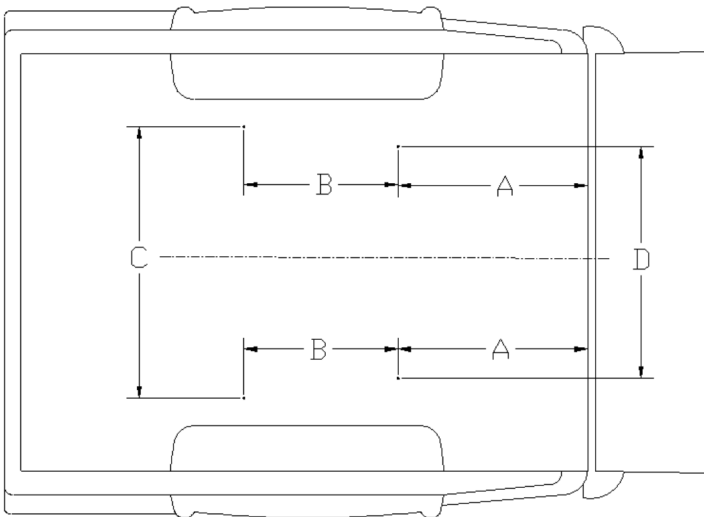

Truck Bed Dimension Table

Layout Method				Template Method	
"A"	"B"	"C"	"D"	"X"	Template Part #
21-1/8"	21-3/16"	41-5/8"	40"	20-1/8"	33150000

Mounting Bracket Installation

Part 1: Bracket Placement & Bed Hole Locations

Some truck beds are not installed square to the frame or are not the same distance from the back of the cab. The steps in Part 1 ensure that the holes in the bed are positioned so the mounting posts line up with the mounting brackets on the frame below the bed.

The basic steps in this section are as follows:

- *Layout the bed holes*
- *Drill the first pilot hole*
- *Check centering using the tape method*
- *Adjust the bed hole layout if necessary*
- *Drill the second pilot hole and check centering to ensure bed hole locations are square to the frame; adjust as needed*
- *Drill remaining holes; check centering*
- *Drill truck frame*

Detailed Installation Instructions

1. Use transparent tape to cover the mounting post hole on the top of each mounting bracket (when the pilot hole is drilled through the bed, the tape will be pierced by the small drill; it should be positioned in the center of the 1" mounting post hole).
2. Align the rear driver side mounting bracket {B} to the existing hole located behind the frame crossmember as seen on pages 6 & 7.
3. Fasten the mounting bracket flush to the frame (some mounting brackets may have a slight warp due to the metal characteristics during the welding process) by using either a clamp or by inserting a fastener through the mounting bracket in the existing frame hole(s). Do not overtighten—you will be removing the brackets in later steps.

WARNING: Prior to drilling any holes, be sure to check the inside of the frame to guard against drilling into the fuel tank, wiring, brake lines or fuel module.

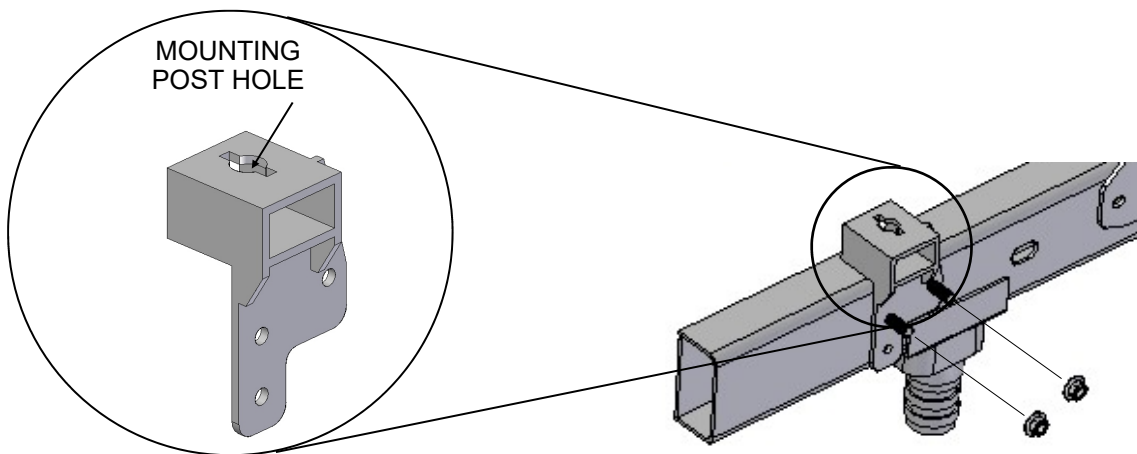

Mounting Bracket Installation

Part 1: Bracket Placement & Bed Hole Locations (cont.)

4. Drill the first 1/16" pilot hole through the truck bed over the rear hole on the driver side where you made the mark during the "Marking Bed for Drilling" on page 3. The bit should come down through the 1" mounting post hole, piercing the transparent tape, aiding the centering of the bracket front-to-rear and side-to-side.
5. If the pilot hole is off center to the 1" mounting post hole, remember to adjust all the pilot hole locations accordingly.

NOTE: Some truck beds are not installed square on their frame by the manufacturer. To ensure your pilot holes are aligned properly, it is important that you use the measurements provided only as a starting point and make adjustments as needed. Once you have the rear driver side pilot hole centered, you will use this hole as a point of reference for all remaining pilot hole adjustments. If you are using the Template Method, simply use the properly drilled hole as a pivot point to square the remaining holes to the frame. If you are using the Layout Method, you may accomplish the same thing by using a framing square and straight edge.

6. Repeat Steps 2-4 for the remaining three brackets, checking each bracket carefully for proper centering.
7. Using the pre-punched bracket holes as a guide, drill 1/2" holes through the outside wall of the frame for all the mounting brackets (see the drawing below).

WARNING: Before proceeding to "Part 2, "Drilling the Bed...", you must verify that each pilot hole is centered over the 1" mounting post hole on each bracket before the 1-3/4" mounting post holes are drilled through the bed.

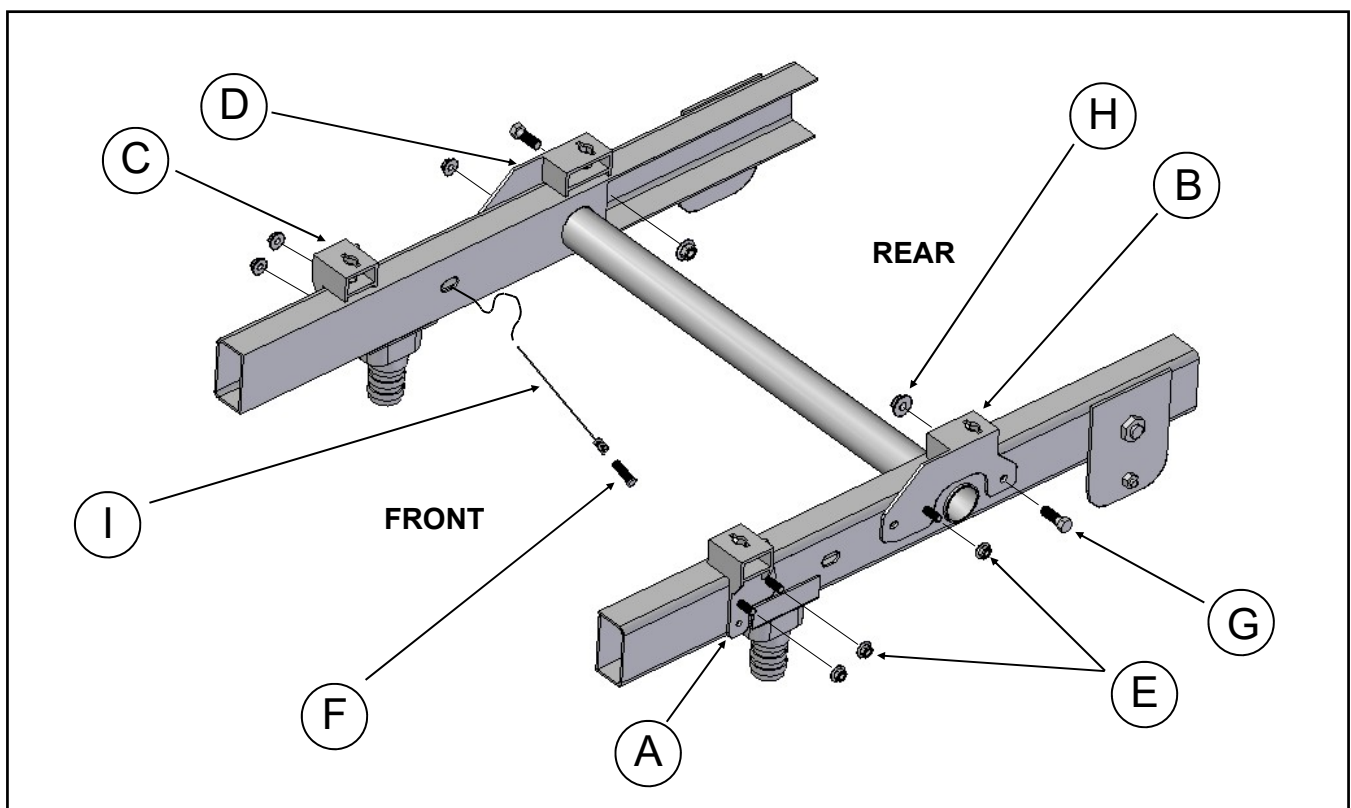

HITCH ASSEMBLY EXPLODED VIEW

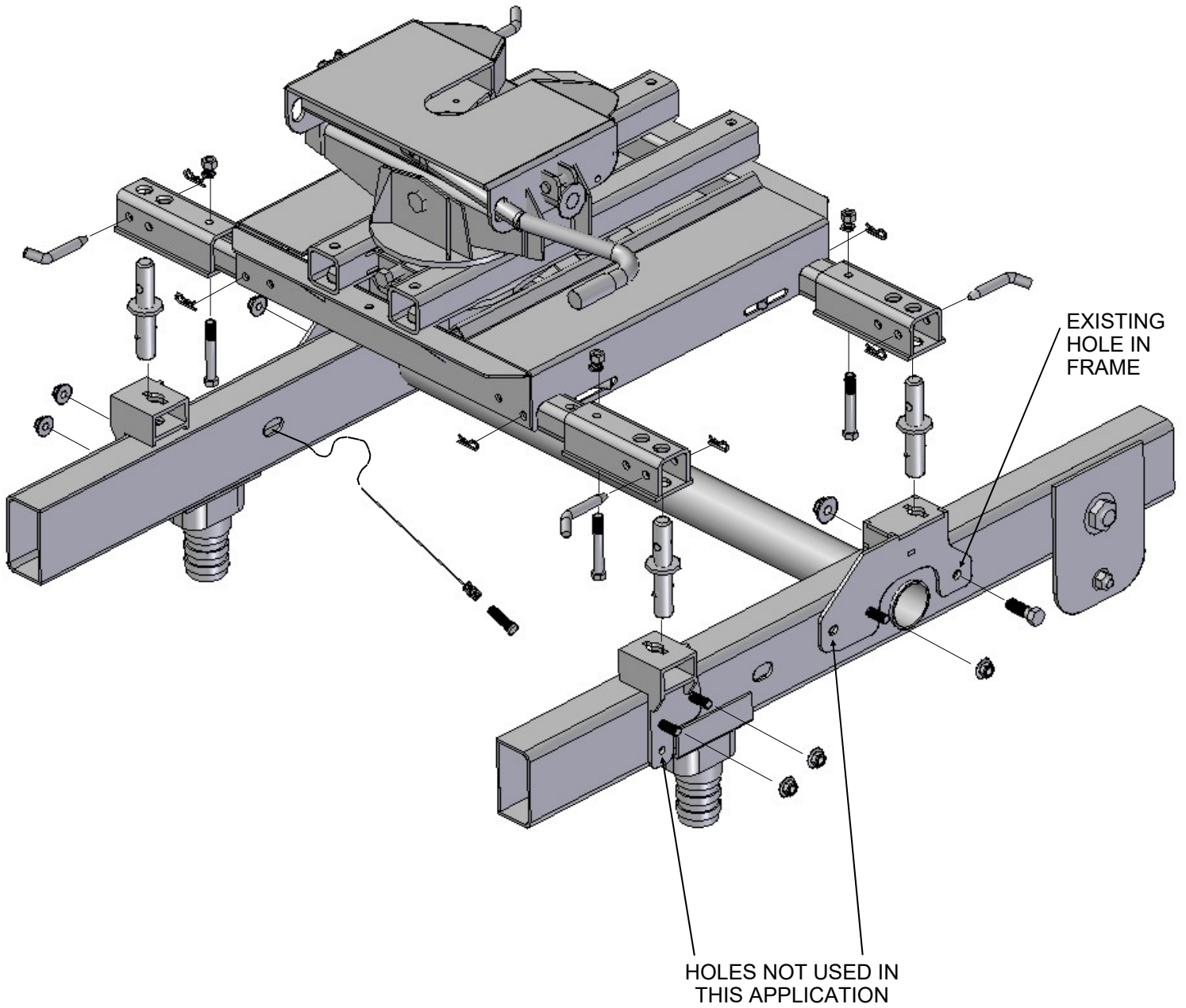

Part 2: Drilling the Bed & Bracket Installation

1. After removing the mounting brackets, use a 1-3/4" hole saw centered over the 1/16" pilot hole and cut the bed for the mounting posts.
2. De-bur inside the holes and use a paint stick to touch up the edges.
3. Fasten the mounting bracket flush to the frame by using either a clamp or by inserting a fastener through the mounting bracket in the existing frame hole(s).
4. The front brackets and the forward-most bolt on the rear bracket are located in the enclosed portion of the frame and require spline frame bolts. Use only the holes indicated on Page 7.
5. Use the spline bolt leader and bolt to fasten the front mounting bracket and the front hole in the rear bracket to the frame (see illustration below).
6. Fasten the spline frame bolts to the previously drilled holes with supplied washers and nuts as seen on Page 7 (finger tighten only). Reuse the bolt leader for each spline bolt. Thread the 1/2" spline frame bolts into the bolt leader and pull through the frame (see illustration below). Finger tighten only.
7. Install the mounting posts through the bed into the mounting bracket post holders. Rotate the posts a quarter turn (see the illustration above). Four posts are required for installation.

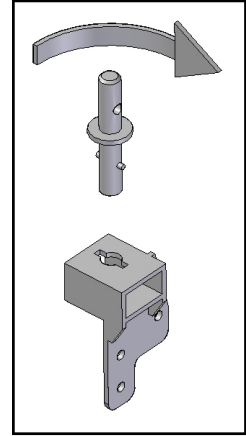

NOTE: Vehicles using plastic bed liners may require taller mounting posts (Part# 330705) to seat properly into the post holders.

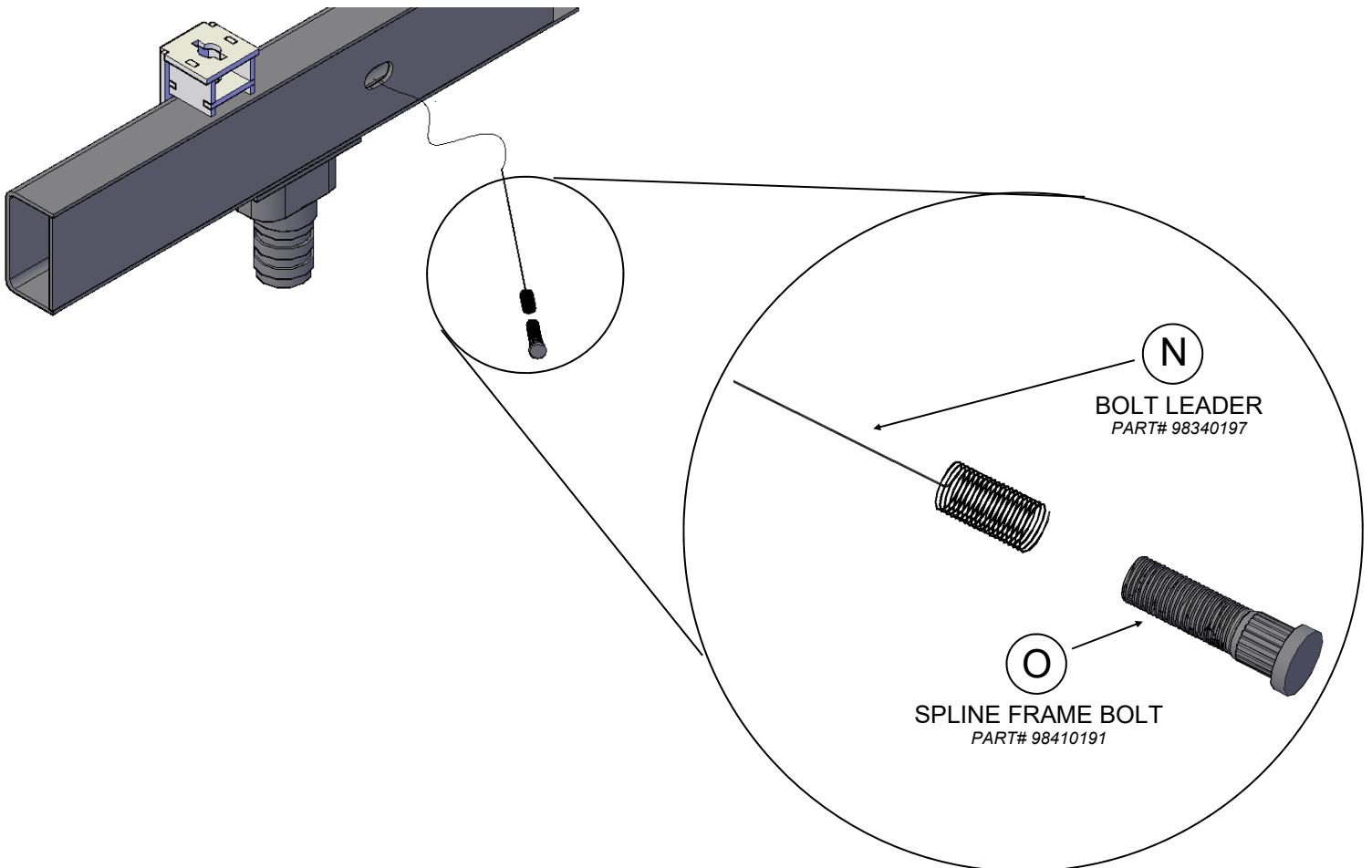

Part 3: Hitch Alignment

1. Remove the SuperGlide hitch from the shipping carton.
2. Secure the base rail extensions to the base rails, leaving the base rail extensions loose to allow lateral movement as you place the rail assembly over the mounting posts (see the illustration to the right).
3. Center the base rails between the mounting posts. Finger tighten the base rail mounting bolts.
4. Set the SuperGlide hitch on the base rails and align the hitch assembly with the mounting holes.
5. Install the hitch pins from the inside. Then install the pin clips, to secure the hitch assembly to the base rails. Use a drift pin to aid your hole alignment.

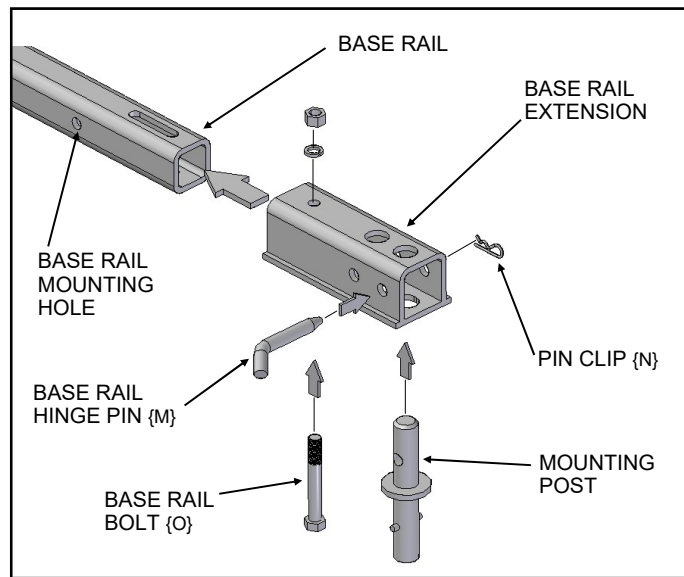

Part 4: Final Installation Procedures

1. Tighten all bolts, including the base rail bolts, according to the Torque Table on Page 4.
2. Remove the hitch and base rail assembly and verify that the mounting posts can be inserted and turned freely without binding. You may need to loosen the bolts on the mounting brackets below if binding occurs. Adjust as needed and retighten the bolts.
3. Reinstall the mounting posts, base rails and the SuperGlide hitch assembly until the assembly can be removed freely without binding.



MANUFACTURED BY:

PULLIAM ENTERPRISES, INC.

13790 East Jefferson Blvd.

Mishawaka, IN 46545

(574) 259-1520 • (800) 443-2307

info@pullrite.com • www.pullrite.com