



# BX2000

## 2010-14 Mercedes Benz Sprinter Van 2500

### Installation Instructions

**Attachment Tab Height: 24"**

**Attachment Tab Width: 20-1/4"**

**Serial Number**

**Please read BOTH these Installation Instructions and the General Instructions prior to installing or operating this equipment.**

1. Blue Ox® towing products and accessories are intended to be installed by Blue Ox® Dealers who are familiar with our products and have the equipment and knowledge necessary to do "fit work". If needed, Blue Ox® Dealers can be found at [www.blueox.com](http://www.blueox.com) or by contacting our Customer Care Department at (402) 385-3051.
2. Many Blue Ox® baseplates are designed to use existing holes and hardware to mount the baseplate to the towed vehicle. Even though bolts are there, do not assume they are adequate for baseplate mounting. Always use the hardware supplied in the hardware kit and existing hardware as specified in the installation instructions.



If the front of your vehicle looks different than this, please contact us at (402)385-3051.

**Reference your vehicle owner's manual for manufacturer's towing specifications.**

**Bolt Torque Specifications**  
Torque in Foot-Pounds for Inch Bolts

Bolt Size	Grade 5	Grade 8
1/4"	10	14
5/16"	19	29
3/8"	33	47
7/16"	54	78
1/2"	78	119
5/8"	154	230
3/4"	257	380

**Bolt Torque Specifications**  
Torque in Foot-Pounds for Metric Bolts

Bolt Size	Grade 8.8	Grade 10.9
6MM	6	8
8MM	16	22
10MM	31	40
12MM	54	70
14MM	89	117
16MM	161	230
18MM	222	318



## WARNING

Failure to read and follow these instructions could result in separation of the towed vehicle from the tow bar, causing property damage, loss of towed vehicle, personal injury or death.

BX2000  
2010-14 Mercedes Benz Sprinter Van 2500  
Installation Instructions

**Instruction Notes:** The fascia is removed and reinstalled for the baseplate installation. Some drilling and trimming is required.

Place all components that are removed on a flat, sturdy surface. All items will be reinstalled unless otherwise noted after the baseplate is installed.

The dimensional variations between otherwise identical vehicles can be considerable. While the baseplate was designed for easy installation, it may be necessary to tailor the baseplate slightly to compensate for vehicle manufacturer's tolerances.

The BX8869 Tail Light Wiring Kit is recommended for this vehicle.

## ***NOTICE***

- Handling of some cosmetic parts when installing this product may require the use of protective covers, rags, specialty tools, etc. to prevent damage.
- When using power drills be aware of the dangers of torque and drill bit length.
- When using a reciprocating saw be aware of objects behind the cutting surface.
- Use a good quality paint to spray cut edges of frame to prevent rusting.
- Be sure that **ALL** electrical connections are plugged in and accessories are functioning properly before reinstalling the fascia.
- The baseplate is computer tested to your vehicle's GVWR, exceeding this weight will void the manufacturer's warranty.
- Be sure to use Loctite® Red on all bolts before tightening. Tighten all bolts according to the torque chart provided.
- Dealer or installer be certain the user receives these instruction sheet.
- If the baseplate is in an accident, it must be replaced. **DO NOT** use it again! An accident can cause unseen damage and using it again could result in more damage or serious injury. **DO NOT** use the baseplate if it is damaged or missing parts.

BX2000  
2010-14 Mercedes Benz Sprinter Van 2500  
Installation Instructions

**Tools Required**

Large Vise Grip  
Utility Knife  
Flat Screwdriver  
Torque Wrench  
Drill  
13/32" Drill Bit  
Tape Measure  
Loctite® RED  
13/32" Drill Bit  
13MM Socket  
8MM Socket  
9/16" Socket  
9/16" Wrench  
T20 Torx  
T25 Torx  
T27 Torx  
T45 Torx

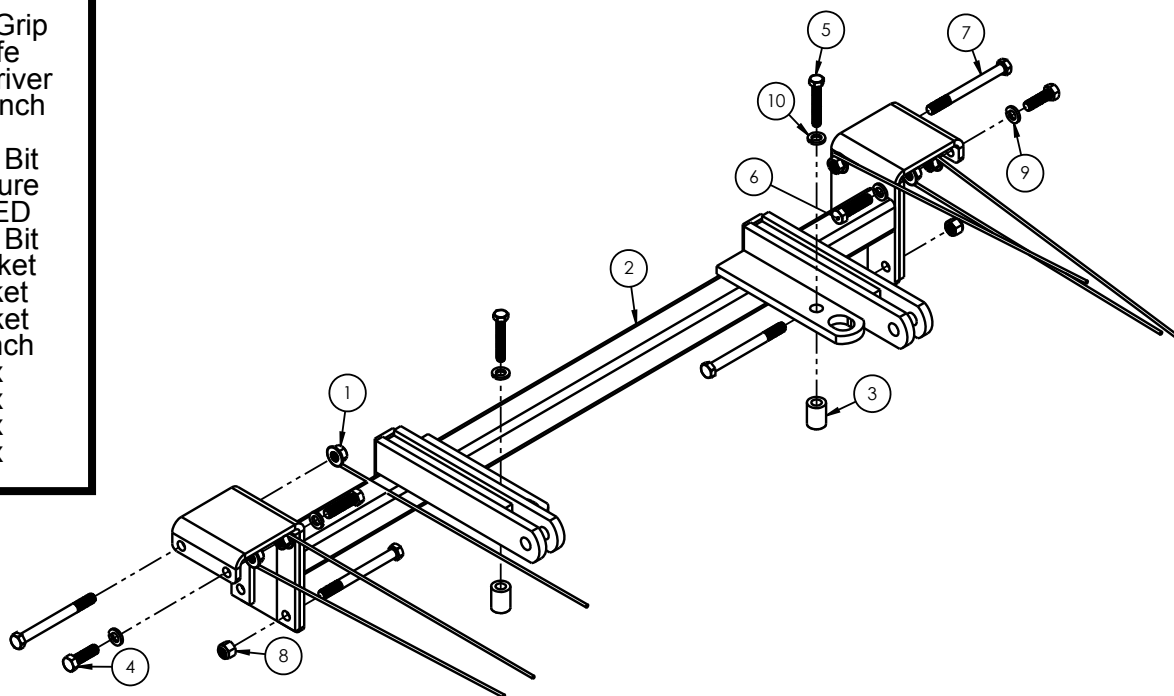

Item No.	Part No.	Description	Qty.
1.....	61-4978 .....	3/8"-16 Whiz Nut, W/14" Wire .....	6
2.....	61-7054 .....	BX2000 Baseplate.....	1
3.....	107-2683 .....	Spacer Tube, 3/4 x .406 (ID) x 1" .....	2
4.....	201-0368 .....	3/8"-16 x 1-1/4 Hex Head Bolt, Grade 5.....	2
5.....	201-0419 .....	8MM-1.25 x 50MM Hex Bolt Grade 8.8, ZP .....	2
6.....	201-0440 .....	3/8-16 x 1-1/2" Hex Bolt Grade 5, ZP .....	2
7.....	201-0618 .....	3/8"-16 x 4" Hex Head Bolt, Grade 5, ZP .....	4
8.....	202-0090 .....	3/8"-16 Hex Nylon Insert Lock Nut, ZP.....	2
9.....	203-0010 .....	3/8" Lock Washer, ZP .....	4
10.....	203-0102 .....	8MM Lock Washer, ZP .....	2

**Important:**

Use only genuine factory replacement parts on your baseplate. Do **NOT** substitute homemade or non-typical parts. If a bolt is lost or in need of replacement, for your safety and the preservation of your baseplate, be sure to use a replacement bolt of the same grade (In most cases it will be Grade 5, please reference the parts list above). Replacement parts may be ordered through your nearest Blue Ox® Dealer or Distributor. Failing to follow and/or altering these installation instructions in either installation or required equipment will void the manufacturer's warranty. Towing behind a non-motorized vehicle will void the warranty.

BX2000  
2010-14 Mercedes Benz Sprinter Van 2500  
Installation Instructions



1. In the front wheel well using a straight screwdriver, turn the two (2) upper and one (1) lower fascia pins 90 degrees to unlock and remove. Both driver and passenger sides.

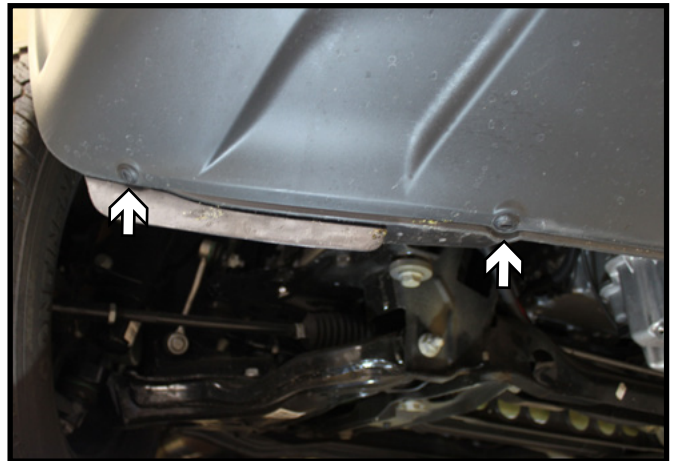

2. At the front of vehicle on the underside of fascia using a straight screwdriver, turn the two (2) fascia pins 90 degrees to unlock and remove. Both driver and passenger sides.

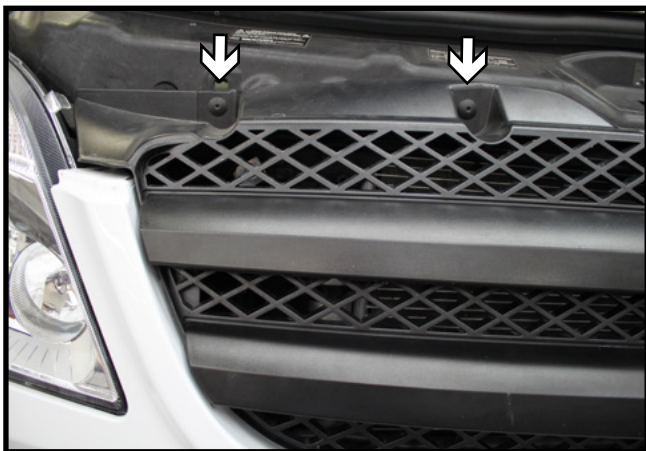

3. On top of the grill locate and remove the two (2) screws using a 25 Torx. Do this on both sides of vehicle. After the four (4) screws are removed the grill can be removed from the vehicle.

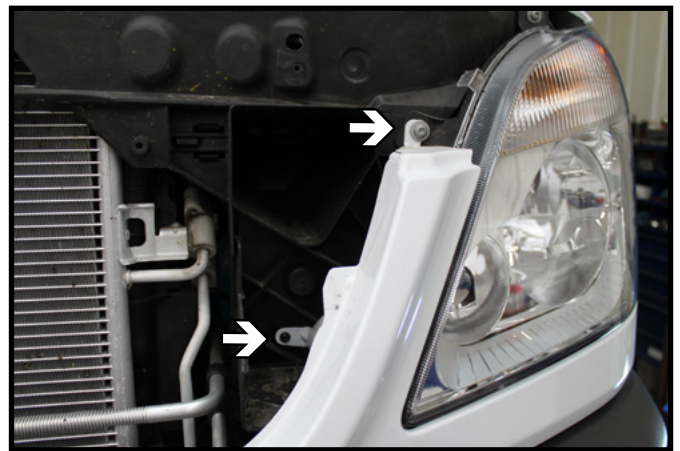

4. Remove the upper screw using a 27 Torx and lower screw using a 20 Torx on both driver and passenger sides.

BX2000  
2010-14 Mercedes Benz Sprinter Van 2500  
Installation Instructions



5. Remove the two (2) screws above the license plate bracket using a 25 Torx.

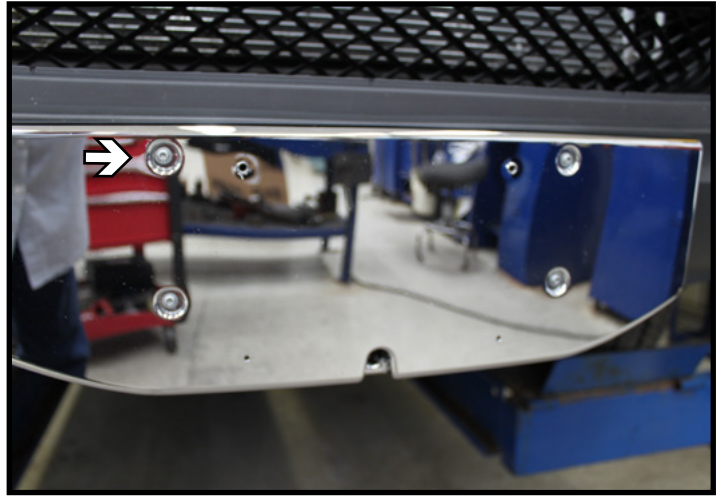

6. Using a 20 Torx remove the four (4) bolts and remove the license plate bracket.

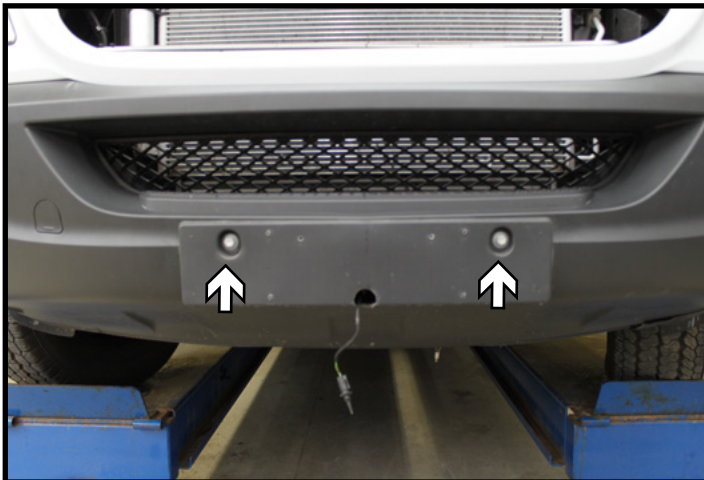

7. Remove the two (2) bolts using a 13mm socket, then remove front fascia.

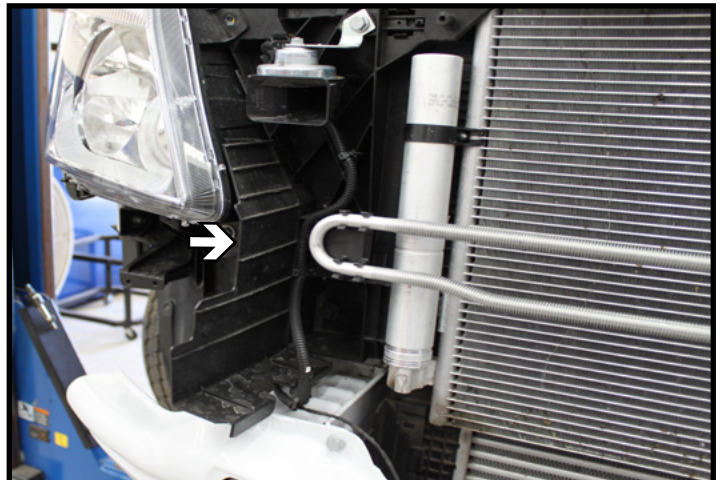

8. Unsnap plastic shrouding on both passenger and driver side.

BX2000  
2010-14 Mercedes Benz Sprinter Van 2500  
Installation Instructions



9. Remove the temperature sensor from bumper (right) then unhook clip from frame (left) and set aside.

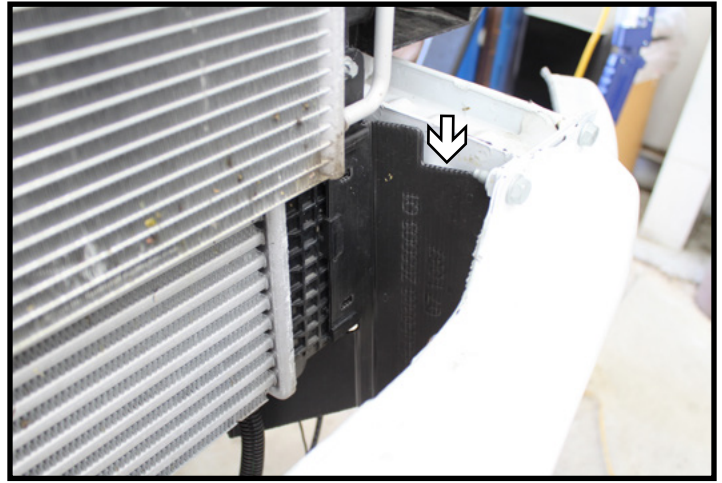

10. Remove cardboard insert from behind bumper on both driver and passenger sides of vehicle.

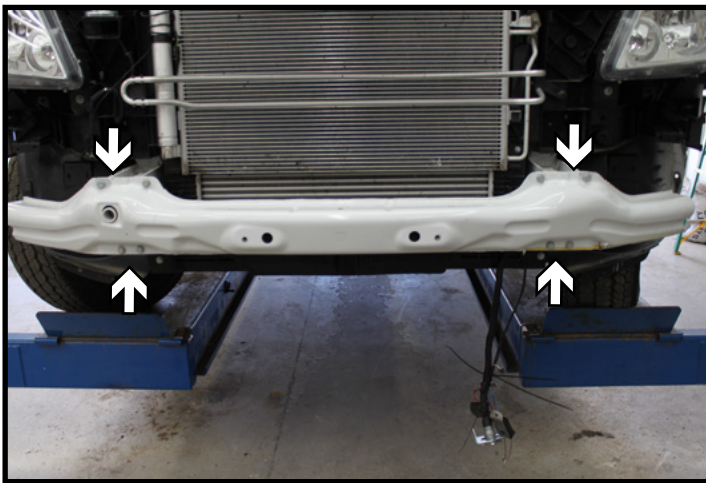

11. Remove the eight (8) bolts using a 13mm socket to remove bumper from frame.

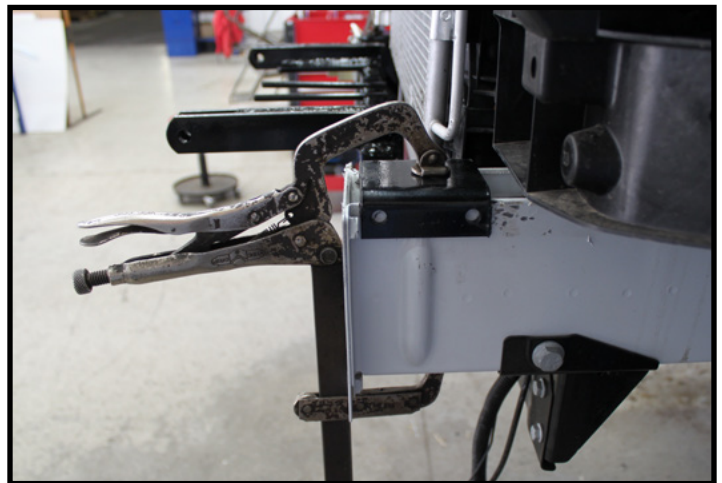

12. Securely clamp the baseplate in place to frame using Large Vise-Grips on both sides of vehicle.

BX2000  
2010-14 Mercedes Benz Sprinter Van 2500  
Installation Instructions

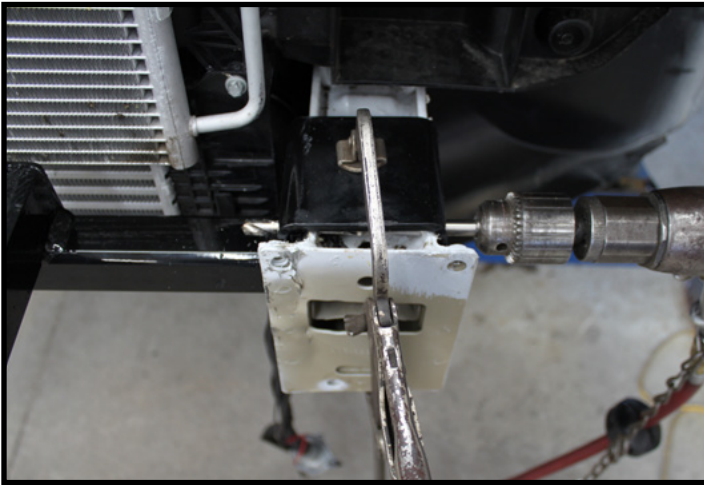

13. Drill the top front hole thru frame using a 13/32" drill bit. DO NOT drill remaining holes at this time.

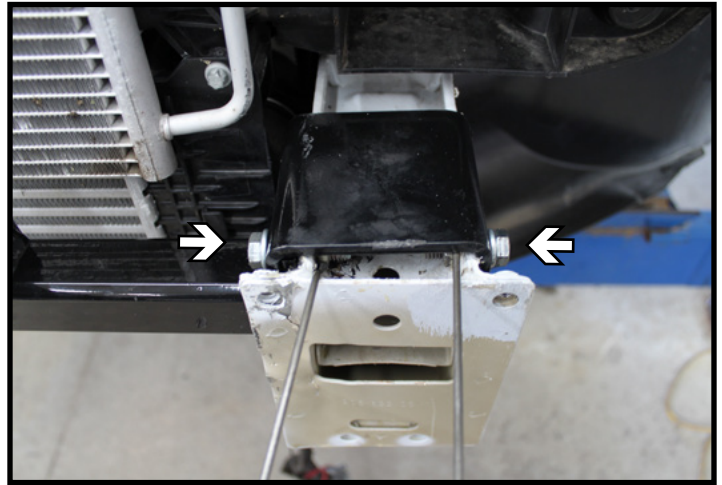

14. On inner frame hole (left) use a 3/8"x1-1/2" bolt, 3/8" lock washer and 3/8"-16 whiz nut. On outer frame (right) use a 3/8"x1-1/4" bolt, 3/8" lock washer and 3/8"-16 whiznut. Repeat on passenger side.

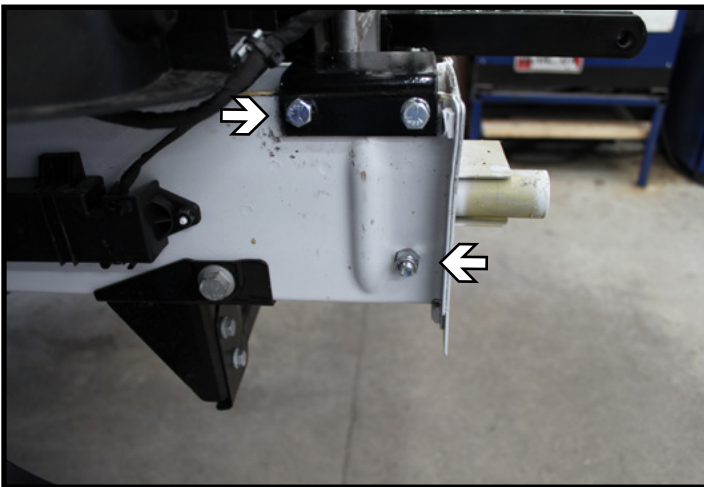

15. After upper front bolts are tightened down continue drilling upper back and lower front holes. In upper back hole (top) use 3/8"x4" bolt, 3/8" lockwasher and 3/8"-16 whiz nut with nut on inner side of frame. On front lower hole (bottom) use 3/8"x4" bolt and nylon lock nut with nut on outer side of frame.

16. Attach the permanent baseplate safety cables to the provided convenience link on the baseplate. Additional options may interfere with suggested mounting; in this case, secure the cables to a solid piece of the frame as described in the instructions included with the permanent baseplate safety cables. Be sure the safety cables do not rub against any hoses or moving parts. Do this on both sides of the vehicle.

BX2000  
2010-14 Mercedes Benz Sprinter Van 2500  
Installation Instructions



17. Hold front fascia up to frame and mark to cut out for clearance around baseplate. After cutting sufficient amount for clearance, re-attach fascia to vehicle.

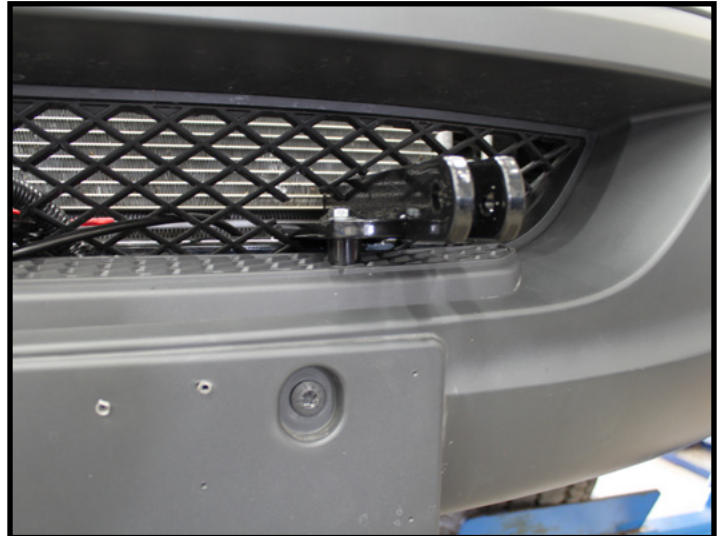

18. Use 3/4" spacertube before installing 8MM-1.25 x 50MM bolt and 8MM lockwasher, typical both sides.

## CUSTOMER SERVICE COMMITMENT

Blue Ox® is committed to providing you with exceptional customer care throughout your lifetime with our products. Our team is here to assist you with any questions you may have regarding the performance of your product. Simply call (402) 385-3051 and you can speak with our customer care team.

Additionally, please visit our website to see which rallies our Destination America team will be attending. For a nominal fee, our service technician will service your towing system to ensure it's in proper working condition. Also, as a commitment to our customers, should you visit our factory, you can stay at our full service Blue Ox® campground at no charge along with enjoying a factory tour.

Again, thank you for being our customer and for the confidence you have shown in the performance of our products. It is because of customers like you we enjoy the success we have today.

© 2014 Blue Ox  
One Mill Road, Industrial Park  
Pender, Nebraska 68047  
Phone: (402) 385-3051  
Fax: (402) 385-3360  
www.blueox.com