

10-1017 INSTALL

PART#: 10-1017



PRINT

Vehicle Application

- YEAR: 2011-2021
- MAKE: Chevrolet / GMC
- MODEL: 2500 / 3500 Crew Cab Short Bed,
- ENGINE: 6.6L Diesel

Required Tools

- Flathead Screwdriver
- Mallet/Hammer
- 15mm Socket
- Ratchet
- 12" Driver Extension

Optional Tools

- Vehicle Lift
- Transmission Jack
- Precision Pick

Before You Start

- Please read the entire product guide before proceeding

- Ensure all parts are present.
- If you are missing any parts, please call or text us at (909)-675-1313
- Do not work on your vehicle while the underbody components are hot.
- Make sure the vehicle is in park or the parking brake is set if you plan on working on the ground. If working on a lift, make sure the vehicle is lifted safely and securely.
- In-bed Auxiliary Fuel Tanks will void the Lifetime Warranty.

Before You Start

Drain your original fuel tank before beginning the S&B Installation process. S&B Tanks recommends removing only an empty or near empty tank for your safety. We recommend using a siphon or electronic transfer pump.

Disconnect and isolate both of the negative battery cables

Before installing S&B Tank, conduct pressure test to ensure o'ring is properly seated.

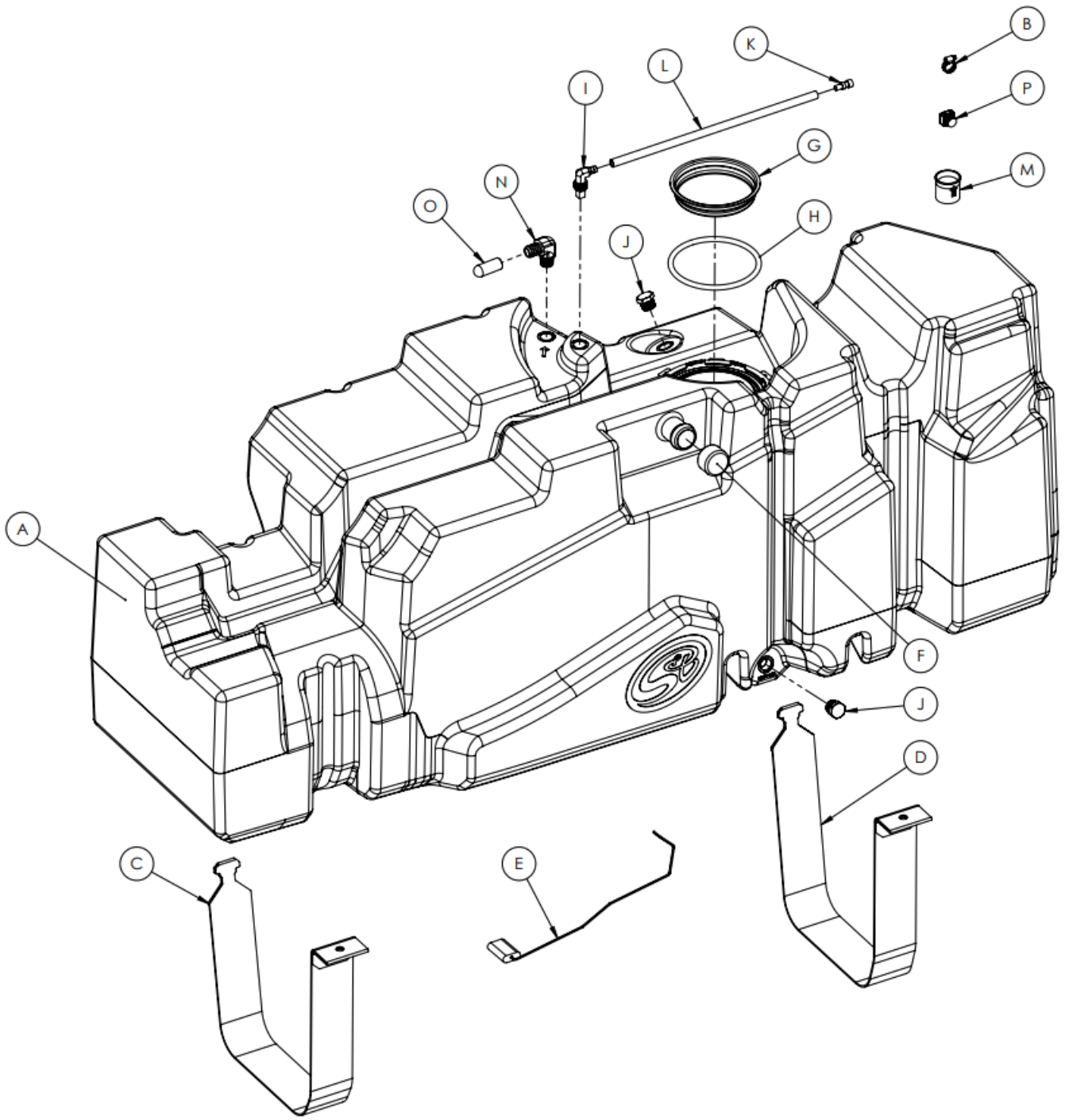

ITEM NO.	PART NUMBER	DESCRIPTION	QTY.
A	10-1017	HIGH CAPACITY REPLACEMENT TANK	1
B	AG1013-00	HOSE CLAMP	1
C	T11084-00	FRONT STRAP FOR 10-1017	1
D	T11085-00	REAR STRAP FOR 10-1017	1
E	float3	FUEL FLOAT ROD FOR 10-1017	1
F	T11092-00	TANK FILLER COVER	1
G	T11093-00	TANK OPENING PLUG	1
H	T11094-00	BUNA-N 50 DURO 8MM CS x 17.32" CUT LENGTH	1
I	T11122-00	ROLL OVER VENT FITTING, 1/2" NPT	1
J	T11125-00	.5" PIPE PLUG	2
K	T11141-00	ROLLOVER VENT CAP	1
L	T11149-15	5/16" FUEL HOSE 15"	1
M	T11175-00	INLET CHECK VALVE	1
N	T11187-00	BARBED VENT FITTING 90 DEGREE ELBOW, 5/8" TO 1/2" NPT	1
O	T11194-00	CHEMICAL RESISTANT RROUND CAP FOR 5/8" OD	1
P	T11195-00	FITTING FUEL LINE QUICK CONNECTOR 5/16" BUNDY FEMALE PLUG CAP	1

INSTALLATION INSTRUCTIONS



STEP 1

Loosen the hose clamps and remove the fill and vent lines



STEP 1 (IMAGE 2)

Loosen the hose clamps and remove the fill and vent lines



STEP 2

Using a precision pick or flat head screwdriver, pull out the red lock on the electrical connector. Then depress the button on the top of the connector and pull the electrical connector off.



STEP 3

Remove the OEM skid plate if equipped. 3 bolts hold on the fuel tank skid plate. This will not be used again.



STEP 4

Disconnect and remove the return and feed fuel connectors.



STEP 4A

The green fuel retaining clip first slides toward the driveshaft then out of the connector.



STEP 4B

Remove this additional bumper bracket found on some 2016 year trucks.

- 13mm Socket
- Ratchet



STEP 5

If you are doing this install on a lift, center the hydraulic jack underneath the fuel tank and raise until the jack contacts the tank. Caution: Support the tank properly as remaining fuel can slosh and cause the tank to shift. If you are doing this install on the ground, support the tank with ratchet straps, floor jack or with a partners hands while you remove the fuel tank straps.

- Lift Install: Hydraulic Jack
- Floor Install: Floor jack with added support to properly hold tank



STEP 6

Remove the 2 bolts that secure the fuel tank straps and then lift our the strap on the driveline side.



STEP 7

With a mallet and pry bar, hit the locking ring counter clockwise to remove the locking ring.



STEP 8

Check the inside of the tank to make sure there are no foreign debris. Place the o-ring in the o-ring groove.



STEP 9

Disconnect the fuel lines from the fuel line retainers on the stock tank. Remove the sending unit and fuel lines from the stock tank. If you are installing this tank on a 2017+ truck, install the included float. Then place the bucket into the S&B Tank with the tab facing the arrow.



STEP 10

Place the retaining ring over the sending unit and push down to get the ring started under the receiving teeth on the S&B Tank. With a pry bar and mallet, hit the ring clockwise until the ring is fully rotated under the indentation.



STEP 11

Install the plugs over the vent rollover valve ports



STEP 11B

Install the rollover valve with the hose facing the filler.



STEP 12

Block off the open ports on the S&B Tank and pressurize the tank through the red filler cover. This is to ensure you got a good seal on the o-ring and there are no leaks. Spray the o-ring area with soapy water.



STEP 13

Install the white inlet check valve into the filler hose before installing the tank. The blue arrow should be pointing into the tank.



STEP 14

Place the tank onto the transmission jack and lift the tank into place. The tank will need to be angled over the driveshaft. The driveshaft can be disconnected from the rear axle and held away from the tank to make this easier.



STEP 15

The vent hose will be installed on the S&B 5/8" barb fitting. When the tank is all the way jacked up into the truck. Measure out the correct length to cut the vent hose and make the cut. Then install the vent hose onto the barb and tighten the hose clamp



STEP 16

Reinstall the electrical connector and slide the red locking tab into the locked position.



STEP 17

Install the S&B Straps. Start by installing the rear strap first. If you are installing this on a 2020+ truck, the included bolt can be used on the front strap to make it easier to install. Putting pressure on the underside of the front strap can help with installation.



STEP 18

Reconnect both fuel line connectors and slide the retaining clips to the locked position. Gently attempting to separate the connectors after they are in the locked position can make sure they are connected correctly.



STEP 19

Reinstall the filler hose onto the S&B Tank and zip tie the breather line onto the filler hose.



STEP 20

This final checklist is very important.

#1 Make sure all bolts and nuts are safely fastened and torqued.

#2 Ensure there is proper driveshaft clearance.

#3 Double check fuel line connections, the electrical connection as well as the vent and fill lines.

#4 Lastly, fill the tank full and check for any leaks.

If you have any questions, call or text us at 909.675.1313

Copyright © 2021 S&B Filters, Inc. - All Rights Reserved

[Terms of Use \(https://www.sbfilters.com/terms-and-conditions\)](https://www.sbfilters.com/terms-and-conditions)

[Privacy Policy \(https://www.sbfilters.com/privacy-policy\)](https://www.sbfilters.com/privacy-policy)

[Sitemap \(https://www.sbfilters.com/sitemap\)](https://www.sbfilters.com/sitemap)